



Instruction

MI 011-477
April 1986

43AP Controller, Style B Servicing



A Siebe Group Company

L.&M.
STRUMENTI DI MISURA Srl
vendite@lemstrumenti.it

Basic Fault Location (Troubleshooting)

Difficulty

No reading (or very low reading) at output gauge.

1. Check that 140 kPa (20 psi) is supplied to controller.
2. Check for measurement reading.
3. Clean restrictor (see page 3).
4. Disconnect output line and plug controller output with finger.

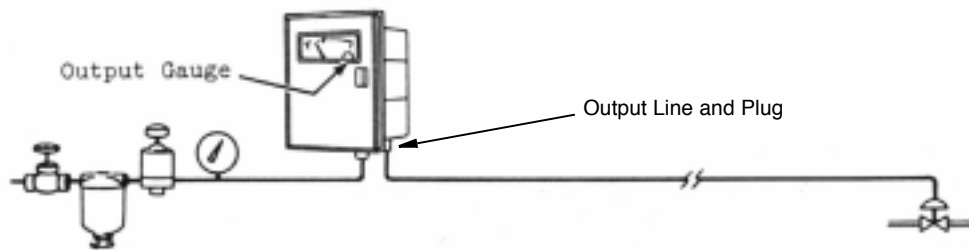

5. Adjust set point knob (or remote set point, if present) so that set point index goes above and below measurement pointer. If output gauge indicates normal control action, there is a leak in output line or valve motor.
6. If output gauge still indicates no control action,
 - a. Check controller for damage or leaks.
 - b. Replace relay (see page 3).
 - c. Check control unit alignment (see page 8 or page 10).

Difficulty

Maximum pressure at all times at output gauge.

1. Check for mechanical damage resulting in nozzle always being covered by flapper.
2. Check for misalignment of relay gasket, resulting in plugging.
3. Replace relay (see page 3).
4. Clean nozzle (see page 4).
5. Check control unit alignment (see page 8 or page 10).

Identification of Major Components in Controller

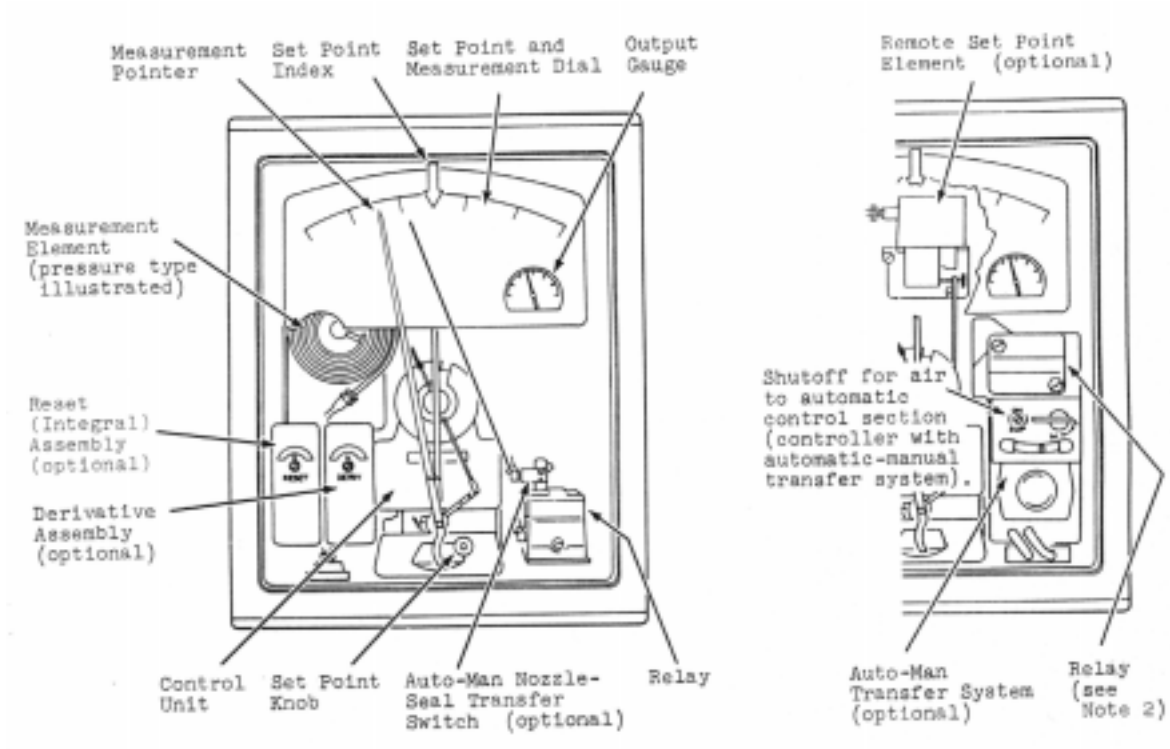

Notes:

1. Controller is equipped with either a locally adjusted set point (set point knob, standard; left illustration) or a remotely adjusted set point (pneumatic set, optional; right illustration).
2. If controller is equipped with optional automatic-manual transfer system (right illustration):
 - a. Relay is located as shown.
 - b. Air to automatic control system can be turned off (see illustration). If automatic control section (relay, restrictor, control unit, etc.) requires servicing, controller can be operated manually.
3. For component connection identifications, see page 12.

Supply Air Filter

Blow out filter at least once a day.



To Clean Restrictor

Restrictor is screwed into base of relay.

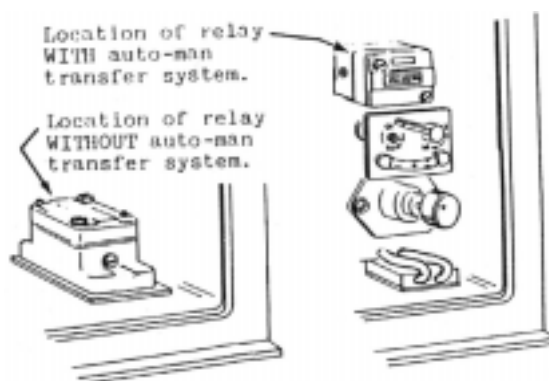

1. Unscrew restrictor. (With restrictor at right, use offset screwdriver.)
2. Clean with 0.005 inch wire or with Foxboro cleaning wire, Part 42527.



3. Before reinstalling restrictor, apply a thin film of petroleum jelly or similar lubricant to O-ring.

To Replace Relay

To remove relay, remove two large screws and pry off. A gasket is supplied with each replacement relay. For servicing details, see Instruction MI 011-493.

Do not remove plate between relay and manifold.

Illustrated is location of relay in controller without auto-man transfer system; for other relay location, see illustration on page 3.

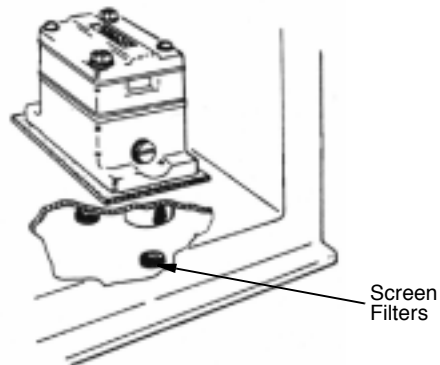

To Replace Screen Filters

If screen filters become clogged, pry out with a pointed tool and replace.

— NOTE —

Filters are always located as shown regardless of location of relay.

To Clean Nozzle

1. Remove screw and washer assembly.

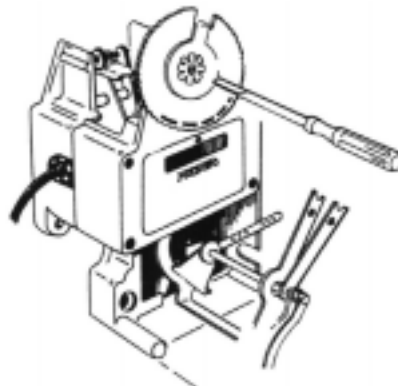

2. Pass 0.005 inch wire (or Foxboro cleaning wire, Part 42527) through opening into nozzle.



3. Replace parts, tightening screw securely.

Controller Identification

When writing to The Foxboro Company, always include controller model and serial numbers found on data plate.

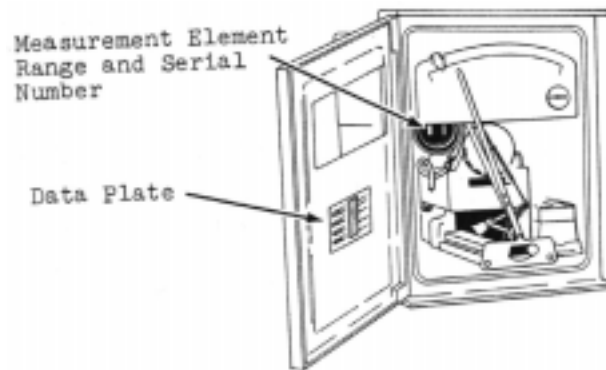

To Remove Measurement Pointer or Set Point Index

Pry lower end of pointer over stud, and slide up. Replace in reverse order.

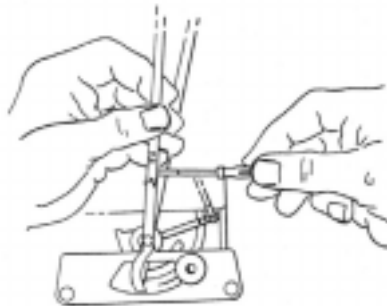

To Remove Control Unit

— **⚠ CAUTION** —

Before tubing is disconnected for removal of control unit, carefully note arrangement of tubing, and identification of tubing at points of disconnection. A convenient place to disconnect tubing is at junction of gray and black tubing.

1. Remove set point index and measurement pointer (see figure above).
2. Remove the two mounting screws.

3. Disconnect measurement link (and remote set link, if present). Note hole that link is in.

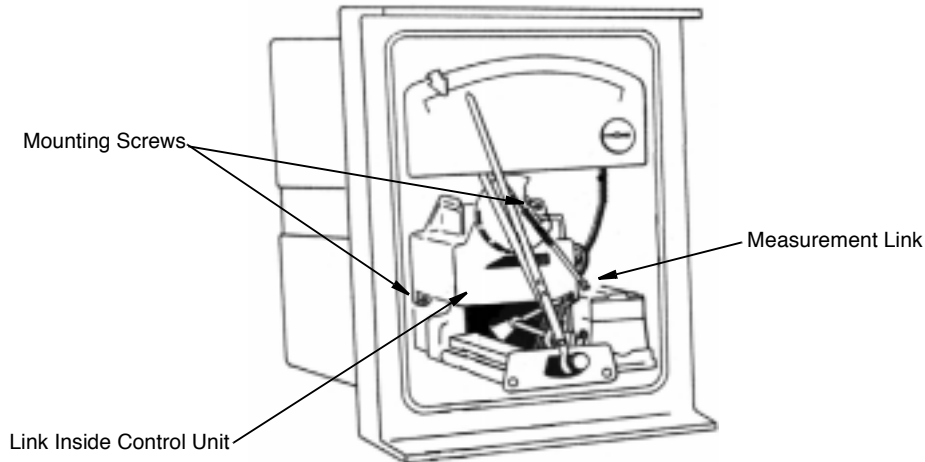

4. If controller has derivative assembly, it will be helpful to remove this assembly. Remove the two small Phillips-head mounting screws and spring back lower mounting bracket.

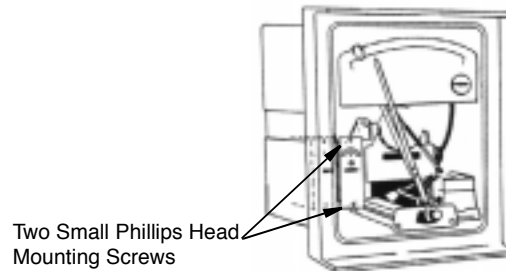

5. Carefully lift up control unit. Break tubing connections where required; see Caution note above.
6. Replace parts in reverse order of removal. It is essential that tubing be reinserted into case as close as possible to its original arrangement. Tubing must not be pinched.

— **NOTE** —

Length of link inside control unit is set at factory and does not require adjustment. If link is replaced, adjust length (ball to ball) to approx. 75 mm (2.9 in), and install on control unit and element connections (use unpainted holes). If alignment on page 8 cannot be made, adjust length of link and repeat alignment procedure.

To Operate with Derivative Units Removed

1. Remove the two small Phillips-head mounting screws. Spring back lower mounting bracket and lift out derivative assembly.

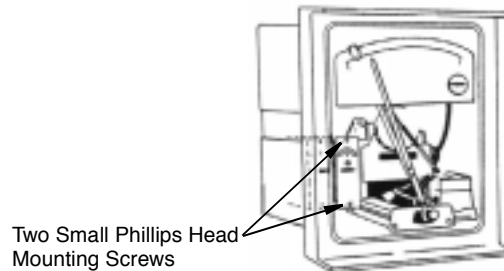

2. With Reset (Integral) Action. Remove tubing from both connections of derivative assembly, and remove lower tubing from tee. Connect upper tubing to tee. Remove derivative assembly from case.

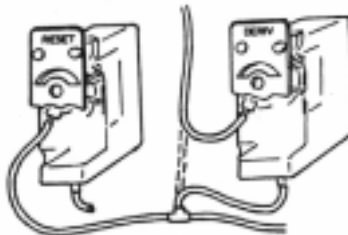

Without Reset (Integral) Action. Remove tubing from both connections of derivative assembly. Connect these two ends together (use coupling, Part C128NE). Remove derivative assembly from case.



Control Unit Alignment

Alignment procedures for On-Off, Differential Gap, and Automatic Shutdown Controllers are on page 10.

Alignment Check and Alignment for Controllers with Proportional, Integral, or Derivative Actions

1. If unit is in service, record settings of set point, proportional band %, integral and derivative (if present) dials.

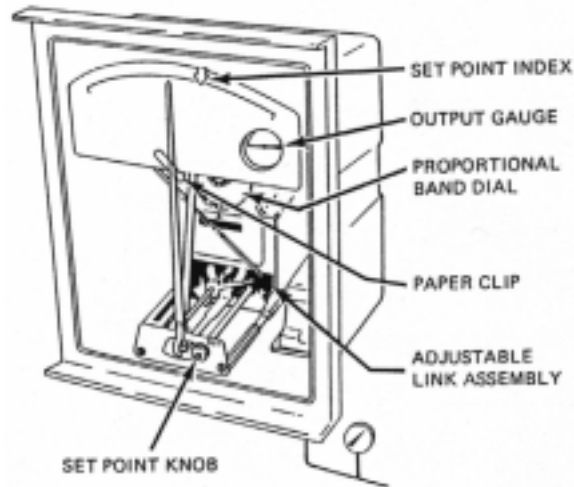

2. If unit has Auto/Manual assembly or transfer switch, place in Auto.

— **NOTE** —

Observe and note the hole the adjustable link assembly is in.

3. Disconnect the adjustable link assembly from link assembly on the control unit.
4. Fasten measurement pointer to dial at midscale with paper clip.
5. Set integral adjustment (if present) at 0.01, and derivative adjustment (if present) at 0.05.
6. Apply 140 kPa (20 psi) supply air to controller.
7. Move proportional band dial to 10% in white sector. Adjust set point knob (or remote set point, if present) so that output gauge is 60 kPa (9 psi).
8. If controller has integral action, wait 10 seconds to allow integral unit to fill with supply air and adjust reset to 50.0.

— **NOTE** —

This locks pressure into integral circuit for alignment procedure. If alignment procedure takes longer than five minutes, the integral adjustment must be set to 0.01 again to allow circuit to fill with air, and alignment procedure must be repeated.

9. Confirm that output gauge reads 60 kPa (9 psi) (adjust set point if necessary), and record position of set point index.
10. Move proportional band dial to 10% in black sector. Note position of set point index.

11. If position of set point index in either Step 9 or 10 differs by more than 2% of scale, alignment must be performed. Complete Steps 12 through 19. If less than 2%, alignment is not required. Proceed to Step 19.
12. Adjust set point knob to move index midway between index readings found in Steps 9 and 10.
13. Perform flapper adjustment as follows, until output is 60 kPa (9 psi):
 - a. Make adjustment in black sector of dial at zero setting.
 - b. Support flapper assembly with finger during adjustment.
 - c. Turn screw clockwise to decrease output.
 - d. Make adjustments in small increments. Withdraw screwdriver and finger to observe result of adjustment.
 - e. Continue until output pressure is steady at 60 kPa (9 psi).

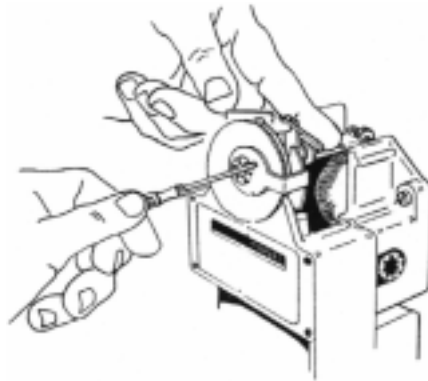

14. Repeat Steps 5, and 7 through 13 until the difference in index positions between sectors (black and white), at 10% proportional, is less than 2% of scale. Then continue at Step 15.
15. With proportional band dial in control sector (white or black) to be used, set dial at 10%. Adjust set point knob so that output is 60 kPa (9 psi).
16. Loosen lock screw and adjust nylon eccentric so that set point index is aligned with measurement pointer.

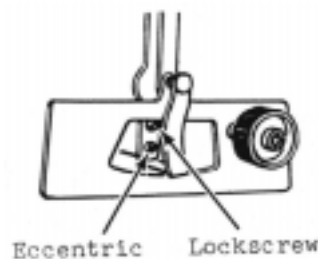

17. Move proportional band dial to 250% in sector to be used. Adjust thumbwheel so that output is 60 kPa (9 psi).

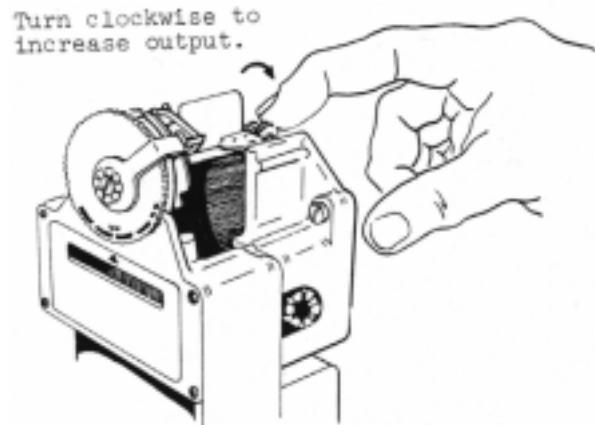

18. Repeat Steps 15, 16, and 17 until output is satisfactory without adjustments.
19. Reconnect measurement link and tubing, and set control dial at desired value.

Alignment Procedure - On-Off and Automatic Shutdown Controllers

1. With control dial set at rectangular mark in sector being used, adjust set point knob (or remote set point, if present) so that output is between 40 and 80 kPa (6 and 12 psi).
2. Loosen lock screw and adjust nylon eccentric so that set point index is aligned with measurement pointer (see bottom illustration).

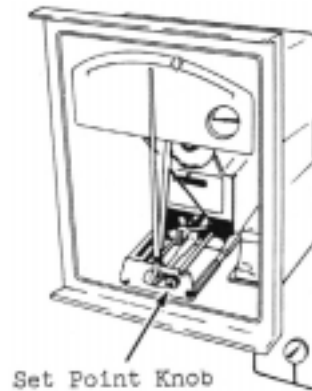

Alignment Procedure - Differential Gap Controller

The graduations on the control dial indicate the approximate gap width. This alignment consists of adjusting the actual gap width and one control point to the desired values.

1. Set gap width dial at desired value and in sector to be used.
2. Disconnect measurement link at control unit. Note hole link is in.

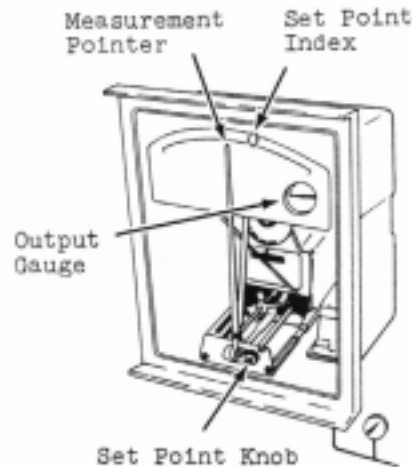

3. If dial is set in black sector, adjust set point knob (or remote set point, if present) so that index is at desired lower control point; if in white sector, at desired upper control point.
4. Apply 140 kPa (20 psi) to controller.
5. Move measurement pointer slowly by hand from one end of scale to other end and then back again. Note scale readings at the two control points (where output changes abruptly); output is either 0 or 140 kPa (0 or 20 psi).

The difference between these readings divided by span is actual gap width.

EXAMPLE: Scale = 20 to 120
 Control points = 70 and 90
 Gap width = $\frac{90 - 70}{120 - 20} = 20\%$

If gap width is not satisfactory, adjust control dial in correct direction and repeat Step 5 until gap width is satisfactory.

6. If control action does not occur at set point index position, readjust the set point knob (or remote set point, if present) until action occurs at correct value of measurement.

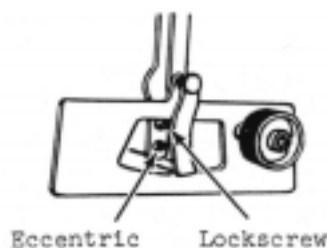

7. Set point index and measurement pointer should coincide when control action occurs. If necessary, loosen lock screw and adjust nylon eccentric to align index with pointer at control point.

Replace measurement link.

Internal Pneumatic Connection Identifications

(If controller has “batch switch,” see illustrations on the following pages.)

Key to Abbreviations	P	Proportional Action
	P+I	Proportional + Integral Actions
	P+D	Proportional + Derivative Actions
	P+I+D	Proportional + Integral + Derivative

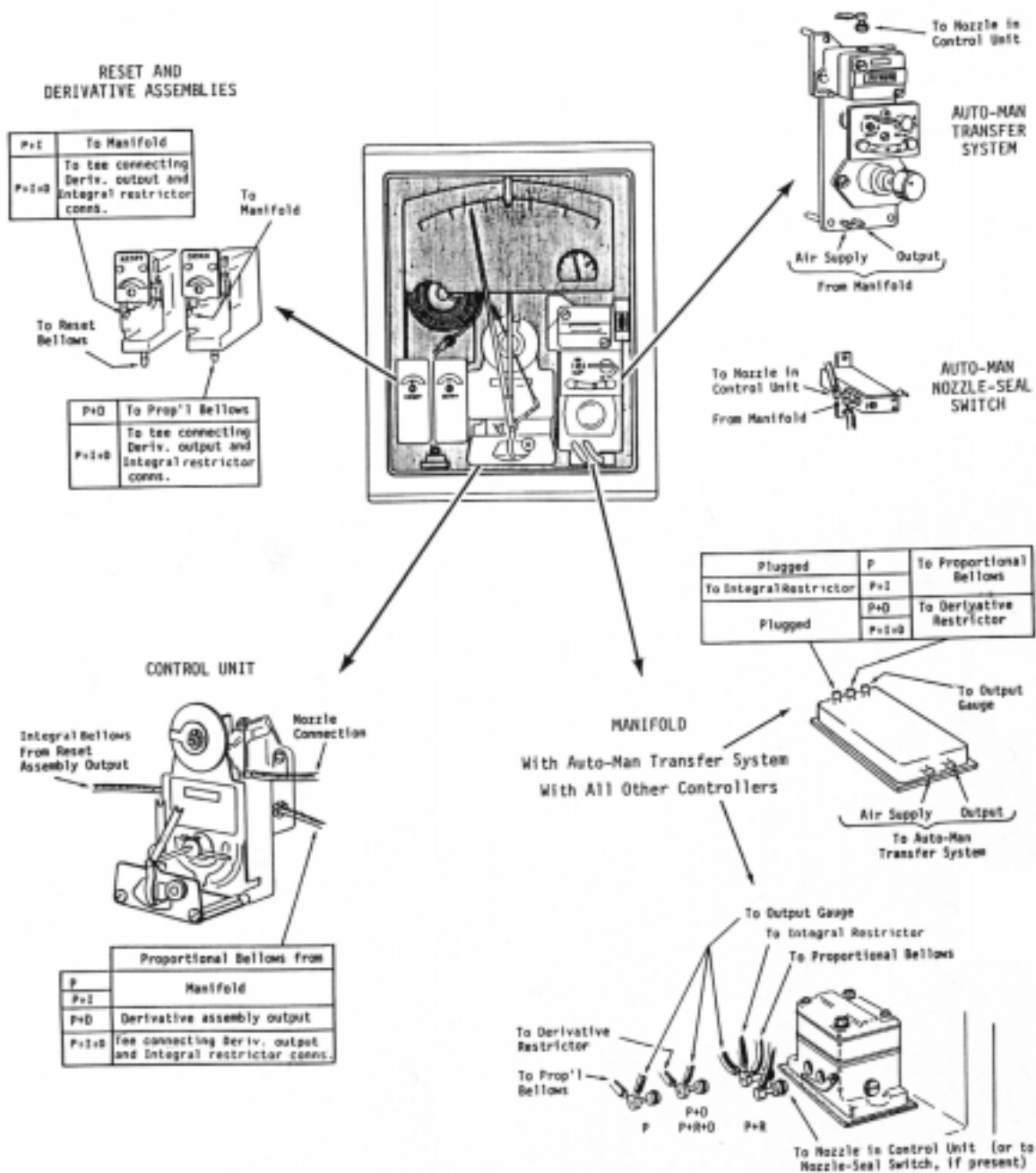

Field Installation of “Batch Switch”

The batch switch is used only in controllers with reset (integral) action. For operation of batch controller, see Instruction MI 11-479, obtainable from Foxboro. For applicable installation procedure, see the following table.

Auto-Man Transfer System	Derivative Action	Use Procedure on
without	without with	page 14 page 16
with	without with	page 18 page 20

The term “batch switch” is used to denote a device which prevents measurement from overshooting set point (controller with reset) when a batch process is restarted. For details of batch controller operation, see Instruction MI 11-479.

Controller WITHOUT Both Automatic-Manual Transfer System and Derivative Action

— **NOTE** —

Batch switch cannot be installed if mounting area is occupied by other component (such as relay contacts, etc.). Before ordering parts, check mounting area (see Step 2 of procedure below).

1. Remove the two mounting screws from scale; remove scale.
2. Connect bracket to mounting plate with two screws (Part 6537); connect batch switch to bracket with two screws (Part 15040).

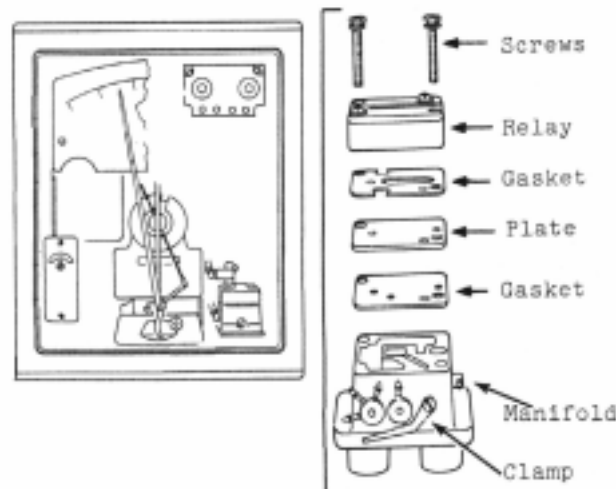

3. Remove the two Phillips-head mounting screws from reset tank. Remove tank by moving outer edge of lower bracket down and away from connector on bottom of tank.

4. Remove the two mounting screws (on underside of controller) from relay assembly; remove relay assembly from controller.
5. Loosen screw in clamp on manifold; swing clamp away from the two connectors. Pry out connectors from manifold.
6. Remove the two large screws form top of relay. Remove old manifold; install new manifold (see assembly of parts).
7. Install the two connectors in new manifold.
8. Cut new tubing to required lengths. Install new tubing and rearrange existing tubing as shown below.

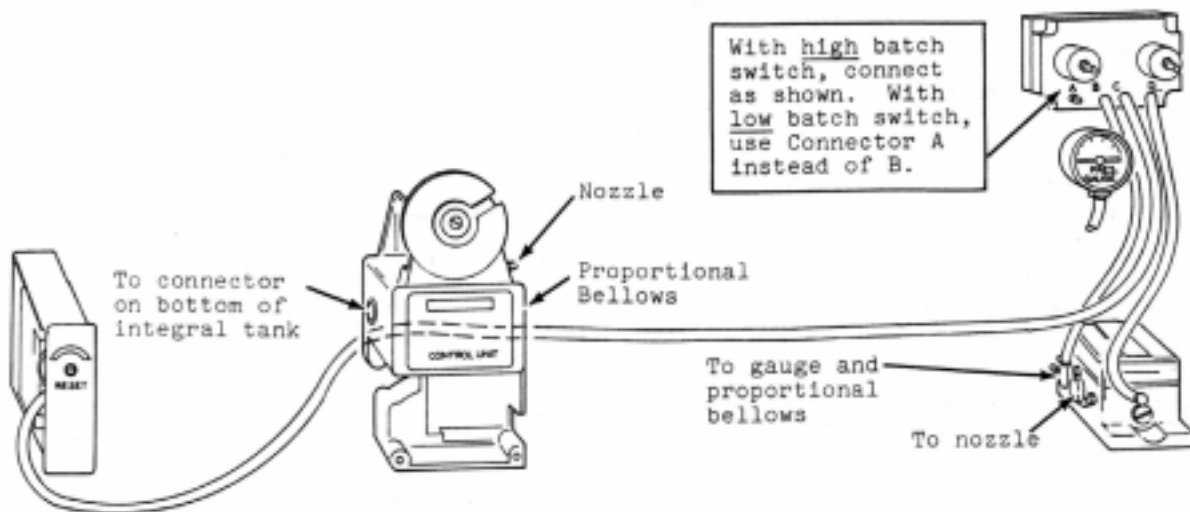

9. Reinstall relay assembly, integral tank, and scale.

Parts Required		
Item	Part No.	Quantity
High Batch Switch or Low Batch Switch	C0143CA C0143DL	1 1
Bracket	C0140QU	1
Relay Manifold	C0140GN	1
Screws	6537	2
Screws	15040	2
Tubing	C0138NZ	1 m (3 ft)

Controller without Automatic-Manual Transfer System, but WITH Derivative Action

— NOTE —

Batch switch cannot be installed if mounting area is occupied by other component (such as relay contacts, etc.). Before ordering parts, check mounting area (see Step 2 of procedure below).

1. Remove the two mounting screws from scale; remove scale.
2. Connect bracket to mounting plate with two screws (Part 6537); connect batch switch to bracket with two screws (Part 15040).

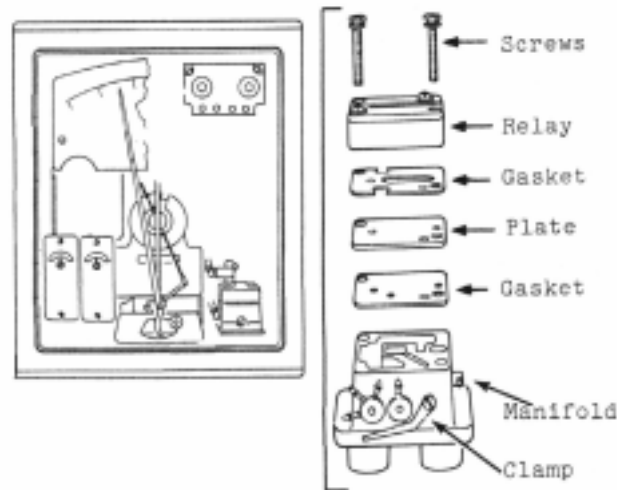

3. Remove the two Phillips-head mounting screws from integral and derivative tanks. Remove both tanks by moving outer edge of lower bracket down and away from connector on bottom of tank.
4. Remove the two mounting screws (on underside of controller) from relay assembly; remove relay assembly from controller.
5. Loosen screw in clamp on manifold; swing clamp away from the two connectors. Pry out connectors from manifold.
6. Remove the two large screws from top of relay. Remove old manifold; install new manifold (see assembly of parts).
7. Install the two connectors in manifold. Use new 3-nozzle connector assembly (Part C0128LW) instead of original 2-nozzle assembly.

8. Cut new tubing to required lengths. Install new tubing and rearrange existing tubing as shown below.

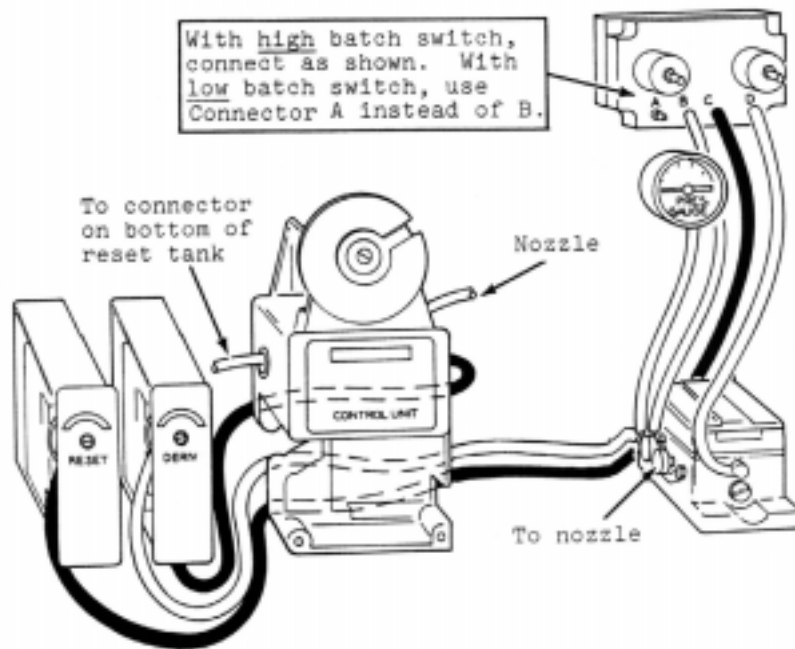

9. Reinstall relay assembly, integral tank, derivative tank, and scale.

Parts Required		
Item	Part No.	Quantity
High Batch Switch or	C0143CA	1
Low Batch Switch	C0143DL	1
Bracket	C0140QU	1
Relay Manifold	C0140GN	1
Connector Assembly	C0128LW	1
Screws	6537	2
Screws	15040	2
Tubing	C0138NZ	1 m (3 ft)

Controller with Automatic-Manual Transfer System, but WITHOUT Derivative Action

— NOTE —

Batch switch cannot be installed if mounting area is occupied by other component (such as relay contacts, etc.). Before ordering parts, check mounting area (see Step 2 of procedure below).

1. Remove the two mounting screws from scale; remove scale.
2. Connect bracket to mounting plate with two screws (Part 6537); connect batch switch to bracket with two screws (Part 15040).

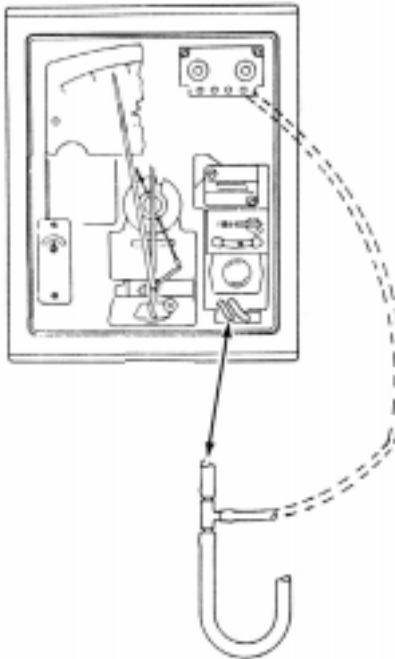

3. Remove the two Phillips-head mounting screws from integral tank. Remove tank by moving outer edge of lower bracket down and away from connector on bottom of tank.
4. Loosen the three Phillips-head screws in mounting plate of automatic-manual transfer system; remove transfer system from controller (disconnect tubing as required).
5. Remove left J-shaped tubing from automatic-manual transfer system. Cut tubing about midway of straight section, and insert tee into tubing as shown. Also cut off about 6 mm (0.3 in) at each end of tubing.
6. Reconnect J-shaped tubing (with tee) to transfer system.
7. Connect about 320 mm (12.5 in) length of tubing from tee connector to Connector D on batch switch.

- Cut new tubing to required lengths (allow slack so automatic-manual transfer system can be reinstalled over tubing). Install tubing as shown below.

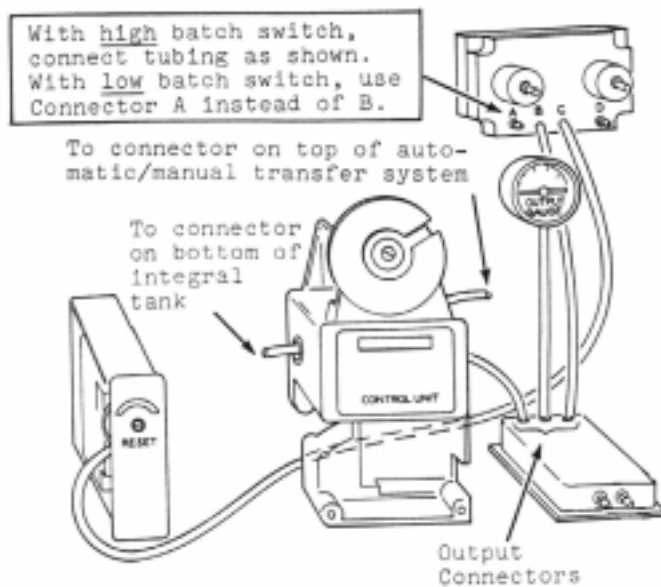

- Reinstall automatic-manual transfer system, integral tank, and scale.

Parts Required		
Item	Part No.	Quantity
High Batch Switch or Low Batch Switch	C0143CA C0143DL	1 1
Bracket	C0140QU	1
Tee	C0138RZ	1
Screws	6537	2
Screws	15040	2
Tubing	C0138NZ	1 m (3 ft)

Controller WITH Both Automatic-Manual Transfer System and Derivative Action

— NOTE —

Batch switch cannot be installed if mounting area is occupied by other component (such as relay contacts, etc.). Before ordering parts, check mounting area (see Step 2 of procedure below).

1. Remove the two mounting screws from scale; remove scale.
2. Connect bracket to mounting plate with two screws (Part 6537); connect batch switch to bracket with two screws (Part 15040).

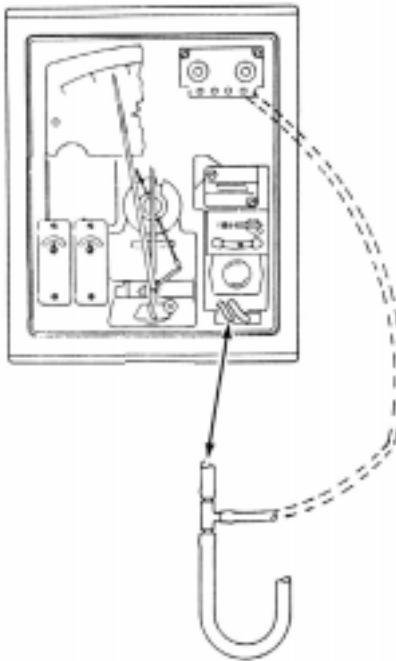

3. Remove the two Phillips-head screws from integral and derivative tanks. Remove both tanks by moving outer edge of lower bracket down and away from connector on bottom of tank.
4. Loosen the three Phillips-head screws in mounting plate of automatic-manual transfer system; remove transfer system from controller (disconnect tubing as required).
5. Remove left J-shaped tubing from automatic-manual transfer system. Cut tubing about midway of straight section, and insert tee into tubing as shown. Also cut off about 6 mm (0.3 in) at each end of tubing.
6. Reconnect J-shaped tubing (with tee) to transfer system.
7. Connect about 320 mm (12.5 in) length of tubing from tee connector to Connector D on batch switch.

- Cut new tubing to required lengths (allow slack so automatic-manual transfer system can be reinstalled over tubing). Install tubing as shown below.

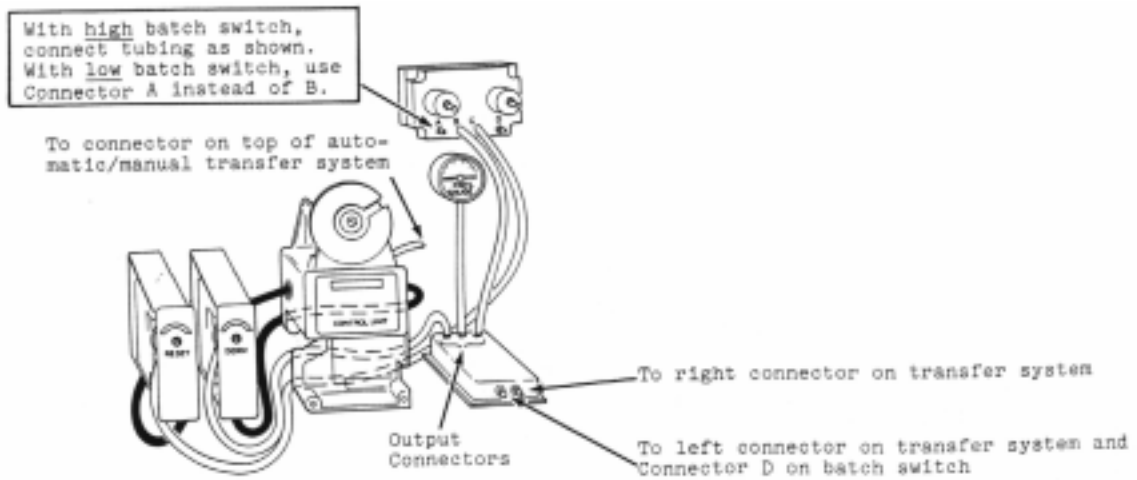

- Reinstall automatic-manual transfer system, integral tank, derivative tank, and scale.

Parts Required		
Item	Part No.	Quantity
High Batch Switch or	C0143CA	1
Low Batch Switch	C0143DL	1
Bracket	C0140QU	1
Tee	C0138RZ	1
Screws	6537	2
Screws	15040	2
Tubing	C0138NZ	1 m (3 ft)

ISSUE DATES

JAN 1975
JUL 1975
JUN 1978
JAN 1984
APR 1986

Vertical lines to right of text or illustrations indicate areas changed at last issue date.

The Foxboro Company
33 Commercial Street
Foxboro, MA 02035-2099
United States of America
<http://www.foxboro.com>
Inside U.S.: 1-888-FOXBORO
(1-888-369-2676)
Outside U.S.: Contact your
local Foxboro Representative.
Facsimile: (508) 549-4492

Foxboro is a registered trademark of The Foxboro Company.
Siebe is a registered trademark of Siebe, plc.

Copyright 1975-1986 by The Foxboro Company
All rights reserved