

IP26 Series Current to Pneumatic Converter



The IP26 (current to pressure) transducer converts a 4–20 mA electrical current signal to a proportionally linear pneumatic output. The unique conversion technology provides a high level of accuracy and repeatability for the operation of actuated valves. A low mass control circuit provides consistent output in high vibration applications. This compact unit is housed in an explosion proof enclosure that is designed for pipe, bracket or direct manifold mounting. This explosion-proof and intrinsically safe field device is available with an integral volume booster.

FEATURES

- 4 to 20 mA, 2-wire Loop powered
- Compact design, small size and low weight
- Approvals Intrinsically Safe and Explosion Proof ATEX, FM and CSA certification
- Position insensitive - Unit can be mounted in any plane and is stable in high vibration environments
- Low power consumption minimize loop load



L.&M.
STRUMENTI DI MISURA
vendite@lemstrumenti.it

Foxboro
by Schneider Electric

INSTALLATION AND APPROVALS

1.1 Pre-Installation Requirements

1.1.1 Environment: Suitable for installation in the following locations:

- Intrinsically safe operation in hazardous locations outdoors (IP65)
- Explosion Proof Installation in hazardous locations outdoors (IP65)
- See section 1.5, 1.6 and 1.7 for ATEX approvals.

The IP transducer enclosure contains aluminum and is considered to constitute a potential risk of ignition by impact or friction. Care must be taken into account during installation to prevent impact or friction.

All wiring must be made to all local and national codes appropriate to the area of installation.

1.1.2 Electrical Input: 4-20 mA dc current source. It is recommended that shielded cable be used and that the shield be grounded to unit and earth ground. See Figure 1 on page 4 for location of ground screw.

1.1.3 Air supply: Clean, dry, oil free instrument air filtered to 40 micron.

Clean all pipe lines to remove dirt and scale prior to installation. Failures attributable to instrument air supply contamination are not covered by the warranty.



1.1.4 For ATEX approved unit, **customer must mark label** by adding a tick mark in the appropriate box that corresponds to the type of hazardous area installation (i.e. Ex d, Ex ia, Ex nAnL or Ex nL). See Figure 2.

1.2 Mounting

1.2.1 The IP26 has been designed to mount inline, to a standard valve yoke (bracket included with unit), or to a 2" (5.1 cm) pipe (optional mounting kit EBZG-IP1).

1.3 Pneumatic Connections

1.3.1 Clean all pipe lines to remove dirt and scale prior to installation.

1.3.2 Supply air must be filtered to 40 microns and free of moisture and lubricants.

1.4 Electrical Connections

1.4.1 The IP26 is supplied with a M20 x 1.5 (ATEX) electrical conduit connection as standard (see Figure 1). 1/2" NPT connection via adaptor AD-A5 (see Model Codes Accessories).

1.4.2 The 2 position terminal block that is wire ready is supplied for 0.34 - 2.5 mm² (22-12 AWG) wire. Wire should be stripped approx. 7 mm (1/4") before insertion. The terminals are labeled "+" and "-" on the terminal board (see Figure 1).

1.4.3 It is recommended that shielded cable be used and that the shield be grounded at the unit (ground screw provided) and to earth ground.

Observe polarity. Reverse polarity will not damage the unit, but unit will not operate.

Conduit should be connected to prevent condensation from collecting in the unit.

Fig. 1: Open cover

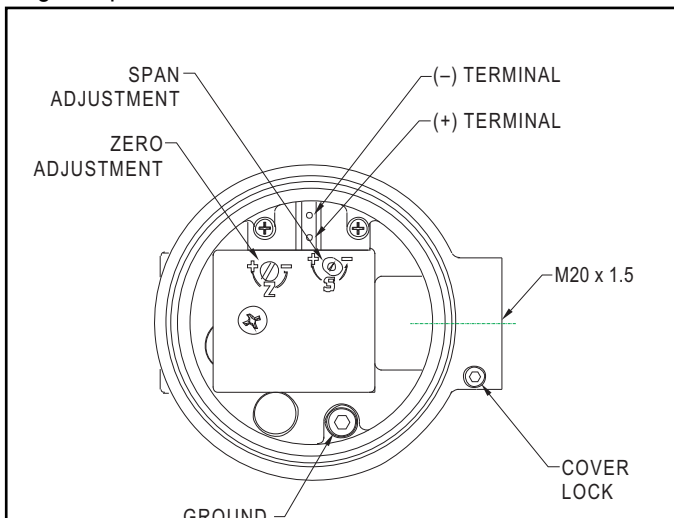

Cover label; for example: ATEX

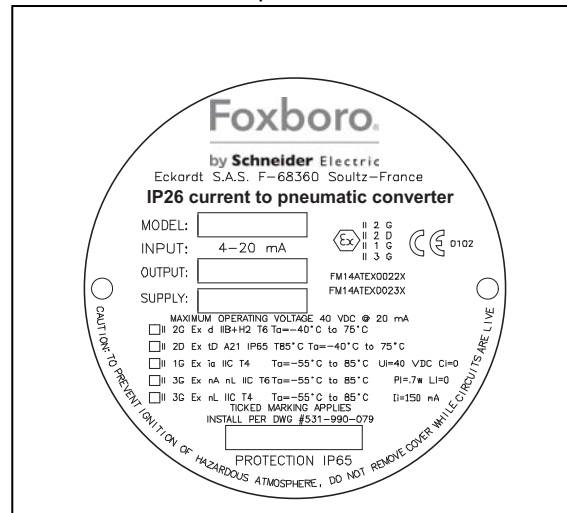

1.5 ATEX Approvals

	Entity Parameters	Temperature Code	Enclosure	Certificate
Intrinsic Safety II 1 G Ex ia IIC	V _{max} = 40 Vdc I _{max} = 150 mA P _i = 0.7 W C _i = 0 nF L _i = 0 mH	T* -55°C to Ta max*	IP65	FM14ATEX0022 X
Flameproof II 2 G Ex d II B + H2 II 2 D Ex tD A21 T85°C	— — —	T6 -40°C ≤ Ta ≤ +75°C	IP65	FM14ATEX0022 X
Limited Energy/Non-Sparking II 3 G Ex nL IIC II 3 G Ex nA nL IIC	— — —	T* -55°C to Ta max* T6 -55°C Ta +85°C	IP65	FM14ATEX0023 X

*See energy limiting parameters. Refer to Certificates of Conformity.

1.6 FM Approvals (FM) & Canadian Standards Association (CSA) Approvals**Intrinsically Safe:**

Class I, Div. 1, Groups A, B, C & D
Class II, Div. 1, Groups E, F & G
Class III, Div. 1, Fibers
Enclosure Nema 4X (IP65)
Rated 4-20mA, 40 VDC Max.
Temp. Code T4 Ta = + 70°C

Explosion Proof:

Class I, Div. 1, Groups A, B, C, D
Enclosure Nema 4X (IP65)
Temp. Code T6

Dust Ignition Proof:

Class II & III, Div. 1, Groups E, F & G
Enclosure Nema 4X (IP65)
Temp. Code T6

Non-Incendive:

Class I, Div. 2, Groups A, B, C & D
Class II, Div. 2, Groups E, F & G
Class III, Div. 2, Fibers
Enclosure Nema 4X (IP65)
Temp. Code T6

Entity Parameters:

V_{max} = 40 VDC C_i = 0 μF
I_{max} = 150 mA L_i = 0 mH

Entity Installation Requirements:

V_{max} ≥ V_t OR V_{oc}
I_{max} ≥ I_t OR I_{sc}
C_a ≥ C_i + C_{cabl}
L_a ≥ L_i + L_{cabl}

Note: Cable capacitance and inductance must be considered when connecting to pressure transducer.

OPERATION**2.1 Calibration**

2.1.1 All units are shipped from the factory calibrated, direct acting.

Factory calibration is susceptible to shift due to handling during transit. Foxboro Eckardt recommends that all units be recalibrated prior to use.

2.1.2 Though the units are shipped fully calibrated it is suggested that the user check the calibration to ensure that settings and operation match the application requirements.

ATEX option units come with a factory installed cover lock screw. Screw must be removed before removing cover. Screw must be replaced upon replacing cover. See Figure 1, Section 1.4 It is not necessary to remove the plastic cover of the unit for calibration.

2.2 Calibration

2.2.1 In direct acting operation the unit is calibrated so that minimum input signal corresponds to minimum output pressure and increasing input signal results in increasing output pressure.

2.2.2 Apply the minimum input signal of the range being used (e.g. 4 mA).

2.2.3 Observe the output pressure. If necessary, adjust the zero screw until reaching minimum output pressure setting. Turn zero screw clockwise to increase and counter clockwise to decrease.

2.2.4 Apply the maximum input signal of the range being used (e.g. 20 mA).

2.2.5 Observe the output pressure. If necessary, adjust the span screw until reaching maximum output pressure setting. Turn span screw clockwise to increase pressure, counter clockwise to decrease pressure.

2.2.6 After setting the span it will be necessary to recheck the zero. Repeat steps 1-4 until both end points are at required values.

MAINTENANCE AND REPAIRS

Under normal circumstances, no maintenance should be required.

3.1 Instrument Air Filtration

- 3.1.1 Failures due to instrument supply air contamination are not covered by warranty.
- 3.1.2 Use of oil and/or water saturated instrument air can cause erratic operation.
- 3.1.3 Poor quality instrument air can result in unit failure. It is recommended that a filter regulator (such as FRS02) be placed upstream of each unit where oil and/or water laded instrument air is suspected.

3.2 Factory Repairs

- 3.2.1 In the event of unit failure, the device can be returned to the factory through point of purchase for warranty repair if the warranty period has not expired.
- 3.2.2 All units returned for repair must be authorized prior to receipt at the factory. Contact a representative at the point of purchase to receive a Return Authorization Number.

3.3 Field Repairs

- 3.3.1 Service kits for elastomer components in the device are available. Consult factory for kit numbers and availability.
- 3.3.2 Replacement components for the device are available. Consult factory for part numbers and availability.

3.4 Filter Replacement

- 3.4.1 Supply pressure can become obstructed should the felt filter element become clogged. To replace filter (P/N: on request), remove slotted plug and carefully remove filter using tweezers. Insure no dust or dirt particles remain in filter chamber. Insert new filter into chamber in orientation as shown in illustration. Replace slotted plug, insuring o-ring is properly seated.

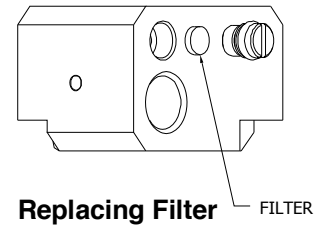

TROUBLESHOOTING

PROBLEM	LOOK FOR	SOLUTION
No or low output	Wires reversed Zero adjustment Clogged filter Supply pressure too low	Reverse input wires (see Figure 1) Reset zero (2.2.3) Replace filter (see Figure 3) Increase supply pressure (see specs)
Unstable / low output	Electrical connection	Check connection/signal (1.1.2)
Erratic operation	Liquid/contamination in air supply Supply pressure	Clean air supply (1.1.3) Verify supply pressure (see specs)
Output equals supply pressure	Improper pneumatic connections	Insure that supply is connected to "IN" port and output is connected to "OUT" port (1.3.3, 1.3.4)

If problems are not solved by troubleshooting procedures, contact your local applications engineer for further assistance.

DISCLAIMER

These products are intended for use in industrial compressed-air systems only. Do not use these products where pressures and temperatures can exceed those listed under.

Before using these products with fluids other than air, for non-industrial application, life-support systems, or other applications not within published specifications, consult your local applications engineer.

Subject to alterations - reprinting, copying and translation prohibited. Products and publications are normally quoted here without reference to existing patents, registered utility models or trademarks. The lack of any such reference does not justify the assumption that a product or symbol is free.

FOXBORO ECKARDT GmbH
 Pragstr. 82
 D-70376 Stuttgart
 Germany
 Tel. +49 (0)711 502-0
 Fax +49 (0)711 502-597
<http://www.foxboro-eckardt.com>

ECKARDT S.A.S.
 20 rue de la Marne
 F-68360 Soultz
 France
 Tel. + 33 (0)3 89 62 15 30
 Fax + 33 (0)3 89 62 14 85

DOKT 558 695 023

