

Accutech AM20

Wireless acoustic monitor field unit





The Accutech™ AM20 wireless acoustic monitor field unit monitors pressure relief valves, steam traps, automatic tank cleaning (CIP) systems, and other applications that generate ultrasound. It can also monitor on/off conditions of compressors and pumps, and can be used for vapor/gas vent determination. The Acoustic Field Unit is suitable for compressible fluid applications.

The effectiveness of the acoustic measurement varies under different industrial environments, but has been demonstrated to work under the following conditions:

- Leak detection, steam: 30PSIG min.
- Leak detection, other gas: 50PSIG min.
- Leak rate: 6 standard cubic feet per hour (SCFH) at 100 PSIG min.

Accutech field units automatically report field data to a centralised Accutech base radio over distances of up to 3000ft (~1000m). Each field unit is self-contained, featuring an integrated 900MHz (license-free band), frequency hopping, spread-spectrum transceiver and antenna, and long-lasting battery that offers 3+ years of maintenance-free service (up to 10 years depending on data rates and battery options). Accutech networks are highly scalable with the possibility of 100 field units per base radio and 256 base radios per installation. Accutech field units are housed within a compact and weather-resistant NEMA4 enclosure with options for a remote sensor and remote antenna on select models. Field units are available in a wide range of certifications and come with a 3-Year warranty (parts and labor).

Product Data Sheet Accutech AM20

Specifications



Accutech AM20

Functional

Sensor Type	Acoustic Monitor
Location	Field Unit
Frequency Range	900MHz license-free band
Power	Integrated battery
Network Capacity	<ul style="list-style-type: none"> Max. 100 field units per base radio Max. 256 base radios per network

Features

Remote Configuration Interface	Accutech Manager, Windows™-based GUI software, providing network-wide monitoring and performance-management features and field unit configuration capabilities.
Local Configuration Interface	<ul style="list-style-type: none"> Integrated LCD with membrane-switch buttons Display provides pressure reading and error messages, if applicable Configure sampling and RF parameters locally using membrane-switch buttons
Acoustic Transducer Characteristic	<ul style="list-style-type: none"> Center frequency: $f_c = 40\text{kHz}$ Bandwidth (3dB): $5\text{kHz} (f_c \pm 2.5\text{kHz})$
Output Characteristics	<ul style="list-style-type: none"> Amplitude is an 8-bit digital output with a scale from 0 to 255 See the Base Radio, Accutech Manager and Output Module descriptions for various analog and digital output options
Sampling and Transmission Characteristics	<ul style="list-style-type: none"> The Acoustic Field Unit samples ultrasound and ambient temperature at regular intervals. The data may then be transmitted to the Base Radio for centralised monitoring and data acquisition. Frequency of process monitoring and data transmission may be set. Ultrasound and ambient temperature monitoring: user designates low rate and high rate conditions Sampling rate: user selectable from 1 to 60 seconds (low rate) and from 1 to 30 seconds (high rate) Transmission rates: user selectable from 1 second to 60 seconds (low and high rate) The Wireless Instrumentation Manager may be used for real-time monitoring of the process information. Thresholds may be set to represent non-standard operational conditions.
RF Characteristics	<ul style="list-style-type: none"> 902MHz - 928MHz band (FCC/IC) 915MHz - 928MHz band (Australia) 915MHz - 921MHz band (New Zealand) Up to 3000ft (~1000m) typical range with obstructions Transmit Power: +13dBm Receive Sensitivity: -113dBm Adjacent Channel Rejection: 48dBc Alternate Channel Rejection: 62dBc
Self-Diagnostics	<ul style="list-style-type: none"> Low battery notification – indicates the need to replace the battery (approximately one month advance notification) Contains software and hardware that continuously monitors operation. Any sensor or device parameter that is out of specification is identified and reported.

General

Operating Ambient Environment	<ul style="list-style-type: none"> -40°C to +85°C (-40°F to +185°F) electronics -20°C to +70°C (-4°F to +158°F) display -40°C to +85°C (-40°F to +185°F) display (extreme cold can reduce LCD visibility) Humidity: 0 to 95 %, non-condensing
Materials of Construction	<ul style="list-style-type: none"> Base Plate: 304 Stainless Steel Cover: GE Lexan®, V-0 rating and UV resistant
Power	<ul style="list-style-type: none"> Self-contained power Standard Accutech AM20 includes a single C-Cell (900MHz) lithium battery that offers battery life up to ten years of service, depending on data rates and battery options.
Operating Shock and Vibration	Tested per IEC 60068-2-6 (vibration) and 2-27 (shock)
Random Vibration Characteristics	Tested to withstand 6 g's, 15 minutes per Axis from 9 – 500Hz
Electromagnetic Compatibility	<ul style="list-style-type: none"> Operates within specification in fields from 80 to 1,000MHz with field strengths to 30V/m. Meets EN 50082-1 General Immunity Standard and EN 55011 compatibility emissions standard.
Certifications	<p>North America HAZLOC:</p> <ul style="list-style-type: none"> cCSAus Intrinsically Safe: Exia IIC; AEx ia IIC Class I, Div. 1, Groups A, B, C & D, T3 Class II, Div. 1, Groups E, F and G, T3 Class III, T3 Class 1, Zone 0, AEx ia IIC, T3 Class I, Div. 2, Groups A, B, C & D, T4 Class II, Div. 2, Groups F and G, T4 Class III, T4 <p>ATEX/IECEX HAZLOC:</p> <ul style="list-style-type: none"> LCIE Intrinsically Safe Ex ia IIC T3 <p>EMC & Radio:</p> <ul style="list-style-type: none"> North America : FCC , IC Europe : CE Mark (R&TTE) Australia: C - Tick

Disclaimer: Schneider Electric reserves the right to change product specifications. For more information visit www.schneider-electric.com.

Product Data Sheet Accutech AM20

Model Code

	TBUAAMTJPN00 represents a typical part number.
Model	Type
TBUAAM	Wireless Acoustic Monitor Field Unit
Code	Select: RF Module Type
T	902MHz - 928MHz band (FCC / IC)
D	915MHz - 928MHz band (Australia)
N	915MHz - 921MHz band (New Zealand)
Code	Select: Certifications
J	<u>Intrinsically Safe Protection</u> cCSAus: see specifications page
Q	ATEX/IECEX: see specifications page
Code	Select: Housing & Battery Pack
P	NEMA4 Polycarbonate Housing with 1 Cell (Available with Intrinsically Safe Rating)
Code	Select: Future Option
N	None
Code	Select: Integral Antenna or Cable & Connector Interface
00	Integral Antenna with NEMA4X Antenna Cover (Available for all safety ratings)

Product Data Sheet Accutech AM20

Dimensions

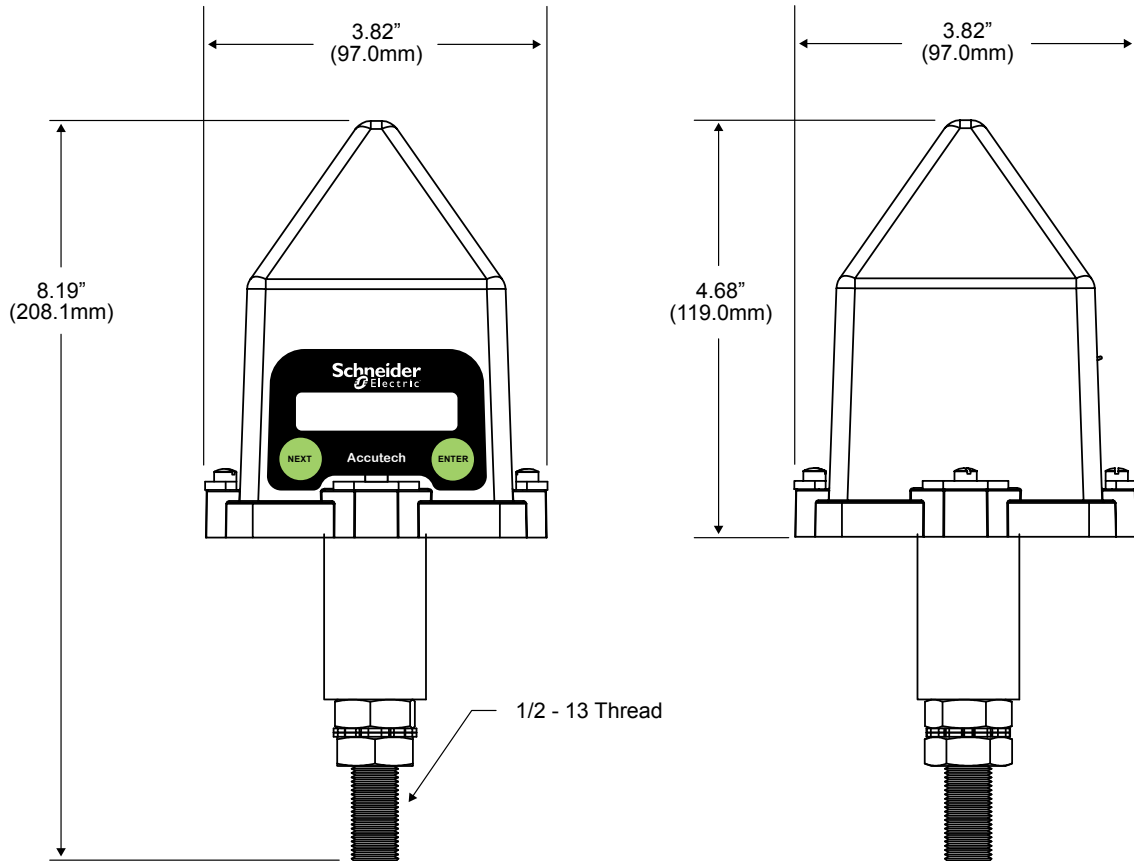

© 2014 Schneider Electric. All Rights Reserved. Schneider Electric, and Accutech are trademarks and the property of Schneider Electric SE, its subsidiaries and affiliated companies. All other trademarks are the property of their respective owners - March 2016

Schneider Electric

Telemetry & Remote SCADA Solutions
415 Legget Drive, Suite 101, Kanata, Ontario K2K 3R1 Canada
Direct Worldwide: 1 (613) 591-1943
Fax: 1 (613) 591-1022
Toll Free within North America: 1 (888) 267-2232
www.schneider-electric.com

