

Accutech DP20

Wireless differential pressure field unit





The Accutech™ DP20 differential pressure field unit provides differential pressure data in a variety of ranges up to +/-300in H₂O. Both traditional (side-mount) and low profile (bottom-mount) connections are available to enhance installation options. The DP20 may be operated in any one of four modes: Differential Pressure, Orifice Flow, Open Channel Flow and Level, and may be configured with a 22-point custom curve capability.

The DP20 is suited for level applications, especially in pressurised tanks (e.g. propane & butane). The product also has a square root function for use with orifice plates, v-cones, and pitot tubes, providing volumetric flow measurement in general industrial processes.

Accutech field units automatically report field data to a centralised Accutech base radio over distances of up to 3000ft (~1000m). Each field unit is self-contained, featuring an integrated 900MHz or 2.4GHz (license-free band), frequency hopping, spread-spectrum transceiver and antenna, and long-lasting battery that offers 5+ years of maintenance-free service (up to 10 years depending on data rates and battery options). Accutech networks are highly scalable with the possibility of 100 field units per base radio and 256 base radios per installation. Accutech field units are housed within a weather-resistant NEMA 4X enclosure with options for a remote sensor and remote antenna on select models. Field units are available in a wide range of certifications and come with a 3-Year warranty (parts and labor).

Product Data Sheet Accutech DP20

Specifications



Accutech DP20

Functional

Sensor Type	Differential Pressure
Location	Field Unit
Frequency Range	900MHz and 2.4GHz license-free bands
Power	Integrated battery
Network Capacity	<ul style="list-style-type: none"> • Max. 100 field units per base radio • Max. 256 base radios per network

Features

Operational Modes	<ul style="list-style-type: none"> • Differential Pressure • Orifice Flow • Open Channel Flow • Level
Remote Configuration Interface	Accutech Manager, Windows®-based GUI software, providing network-wide monitoring and performance-management features and field unit configuration capabilities
Local Configuration Interface	<ul style="list-style-type: none"> • Integrated LCD with membrane-switch buttons • Display provides pressure reading and detected messages, if applicable • Configure sampling and RF parameters locally using membrane-switch buttons

Sensor

Accuracy	± 0.2% of sensor URL including combined effects of linearity, hysteresis, repeatability and temperature (applies to standard unit without isolating seals). Addition of seals will reduce accuracy due to thermal effects of fill fluid. Special ranges and accuracy may be available on request.
Field Spanning	Zero offset (to correct for positioning changes) and two-point (zero and span) calibration
Stability	Combined zero and span stability: less than ± 0.1% of sensor URL per year at 21°C (70°F)
Maximum Static Pressure	3000psi
Differential Pressure Ranges	+/- 100in H2O, +/- 300in H2O, +/- 25psi, -25 to +100psi, -25 to +300psi
RF Characteristics	<p>900MHz:</p> <ul style="list-style-type: none"> • 902 to 928MHz Frequency Hopping Spread Spectrum (FHSS), FCC certified ISM license-free band • 915 to 928MHz (Australia) • Data Rates: 4,800, 19,200 or 76,800bps • 0.4W maximum <p>2.4GHz:</p> <ul style="list-style-type: none"> • 2400 to 2483.5MHz ISM license-free band Frequency Hopping Spread Spectrum (FHSS) Radio • Data Rates: 50/100kbps (FSK Modulation) • Typical Electrical Transmit Power: +10.6dBm • Typical Receive Sensitivity (0.1% BER): -102dBm @ 50kbps, -99dBm @ 100kbps • Typical CW Receiver Blocking Rejection: 64dB for CW @ +/- 5MHz, 74dB for CW @ +/- 30MHz
Self-Diagnostics	<ul style="list-style-type: none"> • Low battery notification – indicates the need to replace the battery (approximately one month advance notification) • Contains software and hardware that continuously monitors operation. Any sensor or device parameter that is out of specification is identified and reported

General

Operating Ambient Environment	<ul style="list-style-type: none"> • -40° C to +104°C (-40° F to +220°F) process connection temperature, steady state • -40°C to +85°C (-40°F to +185°F) electronics • -40°C to +85°C (-40°F to +185°F) display (below -20°C LCD visibility reduced) • Humidity: 0 to 95%, non-condensing
Materials of Construction	<ul style="list-style-type: none"> • Fittings: 316L Stainless Steel • Epoxy coated Aluminum enclosure • Sensor Diaphragm: 316L Stainless Steel (Hastelloy C available upon special request) • Flange: 316L Stainless Steel • Bolts and Nuts: High Strength Alloy Steel
Power	<ul style="list-style-type: none"> • Self-contained power • 1: D Cell, Lithium Thionyl battery • Battery life up to ten years of service, depending on configuration
Sensor Filling Fluid	<ul style="list-style-type: none"> • DC 200 silicone
Operating Shock and Vibration	Tested per IEC 60068-2-6 (vibration) and 2-27 (shock)
Random Vibration Characteristics	Tested to withstand 6 g's, 15 minutes per axis from 9 – 500Hz
Electromagnetic Compatibility	Operates within specification in fields from 80 to 1,000MHz with field strengths to 30V/m. Meets IEC 61000-6-2 General Immunity Standard and IEC 61000-6-4 compatibility emissions standard
Certifications	<p>North America HAZLOC:</p> <ul style="list-style-type: none"> • cCSA_{US} • Intrinsically Safe: Exia IIC; AEx ia IIC • Class I, Div. 1, Groups A, B, C & D, T3 • Class 1, Zone 0, AEx ia IIC, T3 • Class I, Div. 2, Groups A, B, C & D, T4 <p>ATEX/IECEX HAZLOC:</p> <ul style="list-style-type: none"> • LCIE • Intrinsically Safe: Ex ia IIC T3 <p>EMC & Radio:</p> <ul style="list-style-type: none"> • North America : FCC , IC • Europe : CE Mark (R&TTE) • Australia : C - Tick

Disclaimer: Schneider Electric reserves the right to change product specifications. For more information visit www.schneider-electric.com.

Product Data Sheet Accutech DP20

Model Code

	TBUADPTJPN00S100NS represents a typical part number.	
Model	Type	
TBUADP	Wireless Differential Pressure Field Unit	
Code	Select: RF Module Type	
T	902MHz - 928MHz band (FCC / IC)	
D	915MHz - 928MHz band (Australia)	
F	2.4GHz	
Code	Select: Certifications	
	<u>Intrinsically Safe Protection</u>	
J	CSA – see product data sheet for certification details	
Q	ATEX & IECEx – see product data sheet for certification details	
Code	Select: Housing & Battery Pack	
1	NEMA 4X Housing with 1 D Cell	
Code	Select: Future Option	
N	None	
Code	Select: Integral Antenna	
00	Integral Antenna (2.4GHz unit comes default with integral antenna and external antenna connector)	
Code	Select: Sensor Mounting	
S	Integral	
Code	Select: Sensor Range	
	Upper (URL) and Lower Range Limit	Overload Limit
100N	+/- 100in H ₂ O	3000psi
300N	+/- 300in H ₂ O	3000psi
025P	+/- 25psi	3000psi
100P	+100, -25psi	3000psi
300P	+300, -25psi	3000psi
Code	Select: Sensor Type	
S	Standard Sensor - Horizontal process connections with vertical mounting	
L	Low Profile Sensor - Vertical process connections with vertical mounting	

Product Data Sheet Accutech DP20

Dimensions

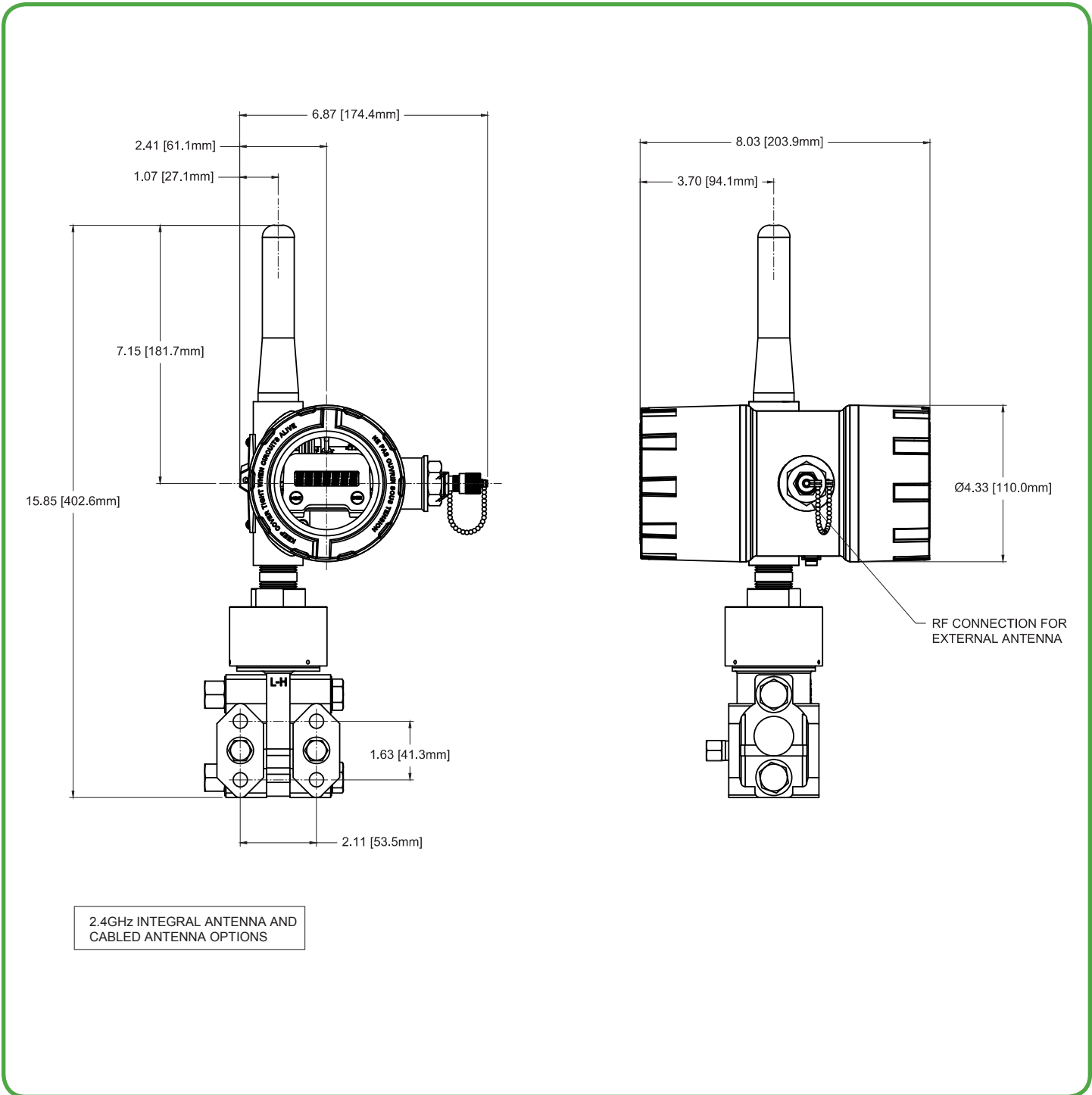

Schneider Electric

Telemetry & Remote SCADA Solutions

415 Legget Drive, Suite 101, Kanata, Ontario K2K 3R1 Canada

Direct Worldwide: 1 (613) 591-1943

Fax: 1 (613) 591-1022

Toll Free within North America: 1 (888) 267-2232

www.schneider-electric.com

