

Partial Stroke Testing for SRD991 and SRD960



Final control elements in Emergency Shutdown (ESD) applications such as ON-OFF-, Blow Down and Venting-Valves remain in one position over a longer time without any mechanical movement. These valves can show the tendency to get stuck and as a result might not operate upon demand. This can have a severe impact on the functionality of a Safety System and could result in an adverse condition to the operating personnel, plant equipment and the environment. The Partial Stroke Test (PST) offers operators a tool to identify the troubleshooting function of ESD valves. The test can be easily executed via the FDT-DTM based configuration and diagnostic tool VALcare™ and Valve Monitor.

MAIN FEATURES

PST Activation:

- Manually on board (LCD + push buttons)
- Automatically
- Through a separate Binary Input for SIS Logic Solver
- LCP960 for local monitoring of PST

Configuration:

- Test Interval
- Setpoint Change
- Maximum Wait Time
- Minimum Pressure

- Testing Status through communication, LCD and Binary Output
- Predictive Maintenance by means of Break Pressure trend, Re-inflate trend
- PST signature
- Complete PST report for print out
- Fail in place (full pressure kept in output when loose of power) or Fail Safe (depressurizing output when loose of power)
- PST for single or double acting Actuator
- PST over HART / Profibus PA and Foundation Fieldbus
- Active Monitoring of SOV (dip detection)
- Trigger capability (monitoring of FST in case of shut down)
- PST feedback over HART using cyclic variables

1 INTRODUCTION TO PARTIAL STROKE TEST:

Safety instrumented systems (SISs), commonly known as emergency shutdown (ESD) or safety interlock systems, are required to be tested at a periodic interval based on their design to assure their functionality and to achieve the required safety integrity level (SIL).

Traditionally, system testing, if it was done at all, was done during unit shutdowns or turnarounds that occurred annually or, for larger units, perhaps every two to three years. These tests are known as Full Stroke Test. Where turnarounds of one or two years have provided adequate opportunity to test full stroke valve functionality at a rate commensurate with the probability-of-failure-on-demand (PFD) requirements of its design Safety Integrity Level (SIL) provide an opportunity for additional testing. Today's longer turnarounds are requiring plant operators to seek ways to test functionality without compromising valve safety availability during normal operation. Extended turnarounds in the process industries have posed a challenge to conventional ESD valve proof testing. Partial stroke testing (PST) emerges as a natural on-line proof-testing complement.

Partial stroke testing is a method where the SIS valve is typically moved 10-20% and returned to its original position in a short period of time. As the most common dangerous failure mode in a static ESD valve is "stuck", on-line partial stroke testing made by the intelligent positioner SRD991 (intrinsic safety application) and SRD960 (Explosion proof application) is the key to the safety.

2 FEATURES

Easy to Use

The SRD positioners can be mounted easily onto any actuator (linear and rotary) of any size thanks to the wide range of attachment kit available.

All the configuration of the PST is very easy to do with our VALcare or Valve Monitor (DTMs) to install into any host supporting FDT-DTM. The configuration windows are simple and intuitive thanks to univocal text and a clear presentation.

The fine configuration of the PST - for example configuration of the type of input, output (how should the switching be, Namur switching or current switching), alarm link - are also possible with the VALcare or Valve Monitor (DTMs).

Configuration and diagnostic can be also done directly onto the SRD and the on-board LCD and push button. The full text LCD display allows the operator to read all status messages and configuration menu in his own language.

Partial Stroke Test

Automatic

Manual:

Time Interval: hours

Setpoint Change: %

Max Wait Time for Position Change: Sec

Air Supply / PST

Lower Limit: bar

<0.LV1256>SRD991 V2 (HART) # Parameter

Identifier | Parameters | Configuration | Characterization | Travel | Alarms | Tuning | Options

Maintenance | Partial Stroke | Pressure | Bin. InOut 1 | Bin. InOut 2 | Friction | LCD

Type

Input Output

Signal Level

Namur (< 1 mA / >= 2.2 mA)

Binary (0 / 40 mA)

Input

Input active Goto 100%

Set Status Binary Input

PST

Invert

Time Saving

The remote testing capability does not require the presence of a technician on the valve during the PST itself. However, technicians still have the ability to perform a PST thanks a push button in the field.

PST Alert

While performing the partial stroke test, if for any reason the valve is stuck, the positioner will abort the test and send a message to request maintenance. An indication of the problem, will appear on the LCD display of the positioner, and the binary output will switch (information for the Logic Solver for example). Through digital communication, the information will reach a DCS or a PC.



On a PC dedicated to maintenance or on the DCS equipped with VALcare or Valve Monitor (DTMs), the information is visualized under the NAMUR NE107 (recommended for diagnostic presentation).

Status	Current	Historical	Category	Description	Action	#
Partial Stroke Testing	(6) Failure	(6) Failure	Process	The Partial Stroke Testings allows to evaluate if an Emergency Shutdown Device (ESD) will operate in case of a safety shutdown. Test was done. Result: Failed	Test showed Error. The ESD capabilities cannot be guaranteed. The valve is stuck and cannot move. The valve needs to be inspected immediately!	64

Moreover this information can be stored and read by a condition monitoring system like Avantis CM (Conditioning Monitoring). The Avantis CM will notify key personnel by email (for example whenever an PST bad status occurs) and recommend a list of corrective actions.

Work Request	Title	Tag #	Tag Name	Requested By	Requested On	Start No Earlier Than	Finish No Later
1150	DMM Condition Monitor-Supply Pressure Warning	FV_225	Positioner, ND9000, Metso Neles	MCX	11/15/2004 11:31	11/15/2004 11:31	11/15/2004 11:31
1149	DMM Condition Monitor-CH1 Input High Wire Open	RTT110	Transmitter, Dual Temperature, Foxboro	MCX	11/15/2004 11:26	11/15/2004 11:26	11/15/2004 11:26
1148	DMM Condition Monitor-CH1 Input High Wire Open	RTT110	Transmitter, Dual Temperature, Foxboro	MCX	11/15/2004 11:16	11/15/2004 11:16	11/15/2004 11:16
1147	DMM Condition Monitor-CH1 Input High Wire Open	RTT110	Transmitter, Dual Temperature, Foxboro	MCX	11/15/2004 11:08	11/15/2004 11:08	11/15/2004 11:08
1129	Valve Sticking	FV201H	Positioner, SRD960 Hart, Foxboro	MCADMIN	11/4/2004 07:14	11/4/2004 07:14	11/4/2004 07:14

Trends

The monitoring of the trends allows you to follow the drift and also to visualize graphically the Test itself.

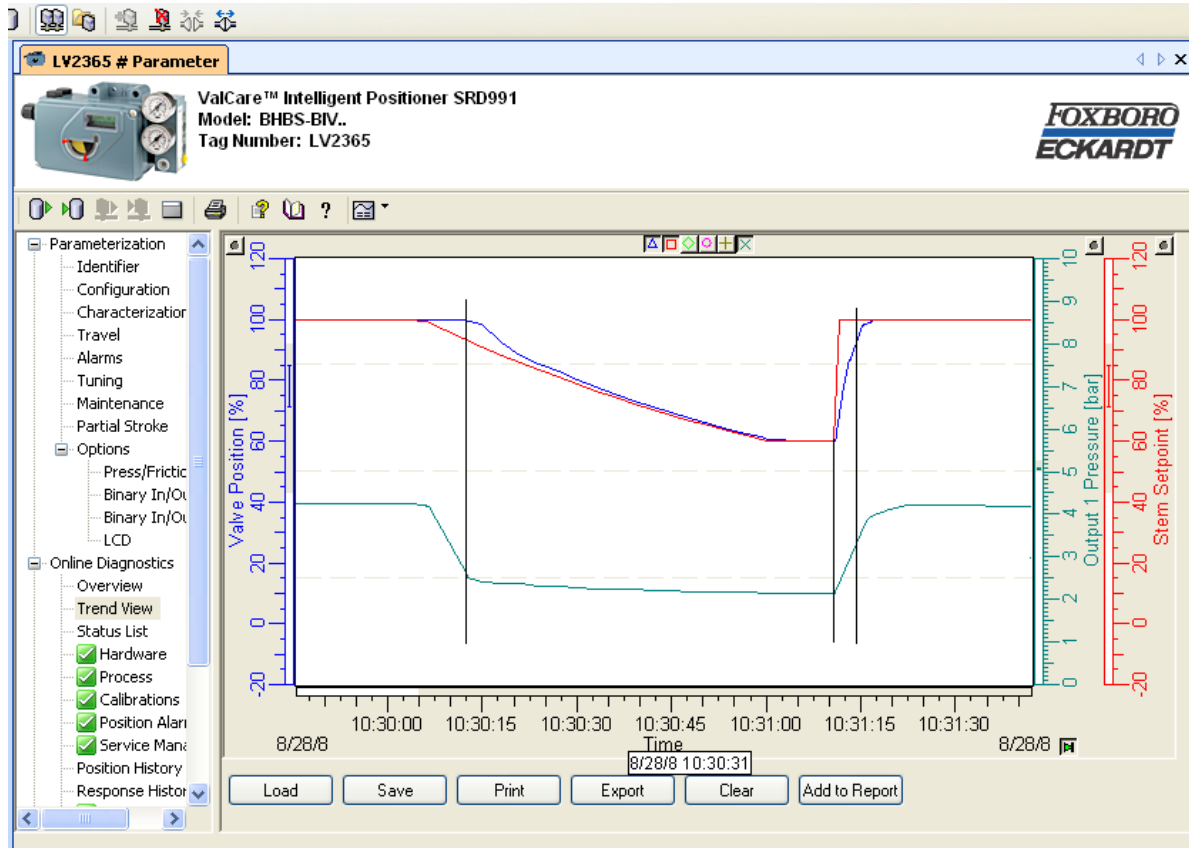

PST Audit Trail

PST audit trail can be done for example by the SOE of the Triconex (Sequence Of Event) or by the DCS thanks to the precise status information provide by the positioner.

Date	Time	Alias	TagName	Variable State	Node	Block
12/07/2006	16:42:23.550				01 - trinode01	01 - EVpstHisto
12/07/2006	16:42:51.050	10003	PST_LAUNCH	START	01 - trinode01	01 - EVpstHisto
12/07/2006	16:42:53.851	10003	PST_LAUNCH	REPOS	01 - trinode01	01 - EVpstHisto
12/07/2006	16:43:17.851	10001	PST_STATUS	PST_OK	01 - trinode01	01 - EVpstHisto
12/07/2006	16:43:17.851	15000	PST_COMPLETED	PST_OK	01 - trinode01	01 - EVpstHisto
12/07/2006	16:43:31.151	15000	PST_COMPLETED	PST_BAD	01 - trinode01	01 - EVpstHisto
12/07/2006	16:51:35.511	10003	PST_LAUNCH	START	01 - trinode01	01 - EVpstHisto
12/07/2006	16:51:35.511	15000	PST_COMPLETED	PST_OK	01 - trinode01	01 - EVpstHisto
12/07/2006	16:51:35.911	10001	PST_STATUS	RUNNING	01 - trinode01	01 - EVpstHisto
12/07/2006	16:51:35.911	15000	PST_COMPLETED	PST_BAD	01 - trinode01	01 - EVpstHisto
12/07/2006	16:51:36.561	10003	PST_LAUNCH	REPOS	01 - trinode01	01 - EVpstHisto
12/07/2006	16:51:54.961	10001	PST_STATUS	PST_OK	01 - trinode01	01 - EVpstHisto
12/07/2006	16:51:54.961	15000	PST_COMPLETED	PST_OK	01 - trinode01	01 - EVpstHisto
12/07/2006	16:52:15.611	15000	PST_COMPLETED	PST_BAD	01 - trinode01	01 - EVpstHisto
12/07/2006	16:52:54.262	10003	PST_LAUNCH	START	01 - trinode01	01 - EVpstHisto
12/07/2006	16:52:54.262	15000	PST_COMPLETED	PST_OK	01 - trinode01	01 - EVpstHisto
12/07/2006	16:52:54.662	10001	PST_STATUS	RUNNING	01 - trinode01	01 - EVpstHisto
12/07/2006	16:52:54.662	15000	PST_COMPLETED	PST_BAD	01 - trinode01	01 - EVpstHisto
12/07/2006	16:52:55.912	10003	PST_LAUNCH	REPOS	01 - trinode01	01 - EVpstHisto
12/07/2006	17:08:41.330	10003	PST_LAUNCH	START	01 - trinode01	01 - EVpstHisto
12/07/2006	17:08:43.080	10003	PST_LAUNCH	REPOS	01 - trinode01	01 - EVpstHisto
12/07/2006	17:08:55.280	10001	PST_STATUS	PST_OK	01 - trinode01	01 - EVpstHisto
12/07/2006	17:08:55.280	15000	PST_COMPLETED	PST_OK	01 - trinode01	01 - EVpstHisto

Predictive Maintenance

Advanced diagnostic capabilities accessed via digital communication (HART for example) allow predictive maintenance thanks to trend analysis. The easy user interface inside the DTM (VALcare or Valve Monitor) enables the operator to understand immediately if there is a drift in the behaviour.

The Monitoring of the Break Pressure (Trend) enable to follow an eventual drift of the friction at valve 100%.

The Monitoring of the Re-Inflate Time (Trend) enable to follow the drift of the friction on the PST and also the status of air supply.

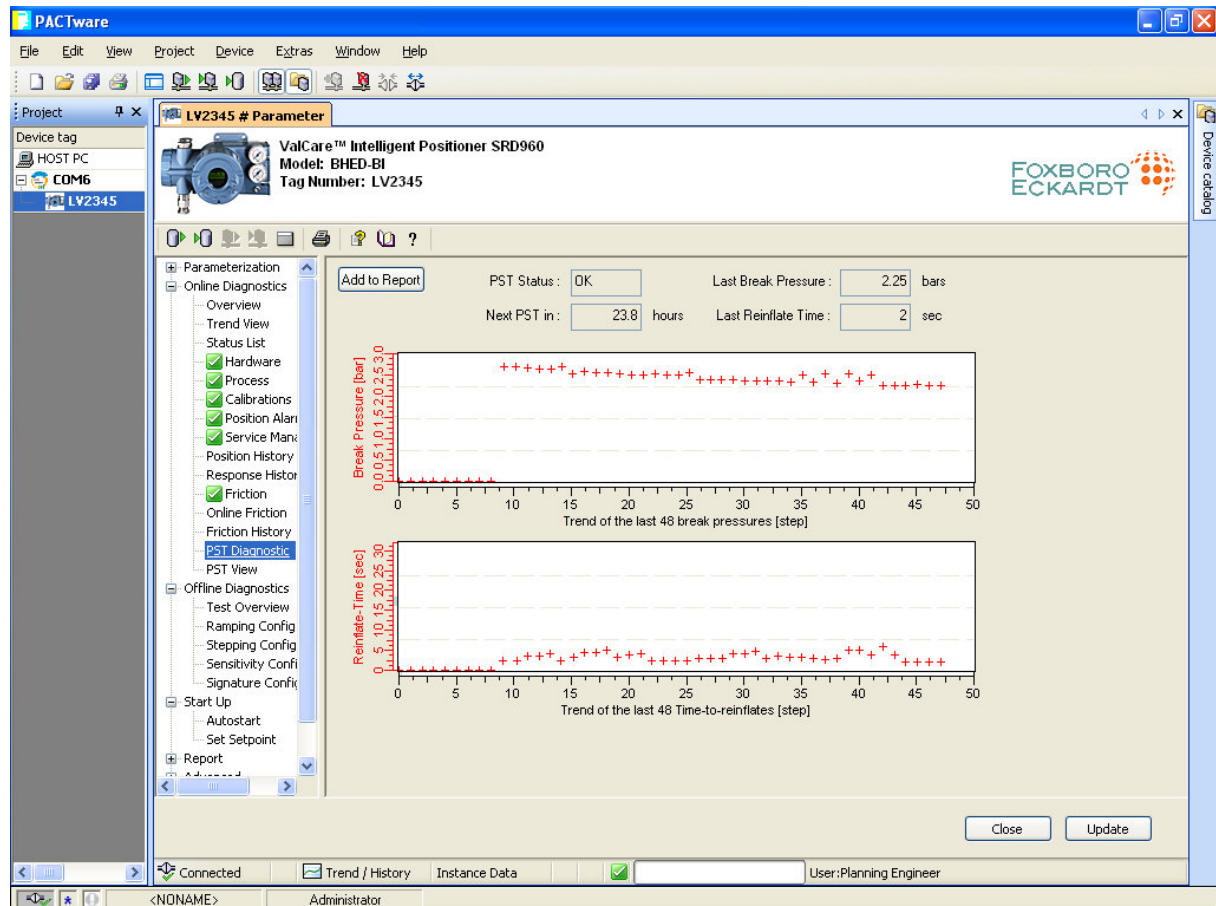

Continuous Auto Check

During the test, the positioner checks all control parameters as well as the functionality of all pneumatic and electrical components. Even if the positioner in the normal position doesn't control the position and provide full output pressure, the positioner continuously checks the proper workings of all electronic parts and electrical connection between electronic, option board, potentiometer and I/P converter. All this enables in connection with the Alarm Link Scheduler the precise configuration of the Alarm that switches the binary output.

Pressure Control Active

At any time the positioner monitors the input and output pressure. If the input air supply pressure fall below a certain level, an alarm can be set to indicate that some maintenance should be done on the air supply line. On the output pressure, a minimum pressure is also set in order to interrupt the PST. Like this positioner avoids in case the valve stuck a possible overshoot.

Soft PST

Slow and Accurate, the Soft PST function allows to perform the change of setpoint of the PST with a very low speed. A PST ramp can be configured up to 100 s in order to avoid any chock given by the fast closing or opening. Soft PST function is also an additional safety to protect the valve against any overshoot in case of increasing friction. Of course in case of emergency the valve will close or open at maximum speed!

High Safety in Test

The test can be requested by the SIS Logic Solver itself and the information on the status of the test can be read also by the Logic Solver. Such types of architecture developed in collaboration with Triconex eliminates any human decision or intervention; and like this, as described by the IEC61508 and IEC61511, allows the system to reach the highest level of safety.

Developped with



This architecture doesn't use HART or any of the particular Invensys protocols which are not certified SIL but simple binaries input and output. It is important to notice that no additional electronic equipment (like HART splitter) is necessary. Only a direct connection through binaries input-output of the positioner with the Logic Solver is necessary. This solution is available regardless of the communication protocol!

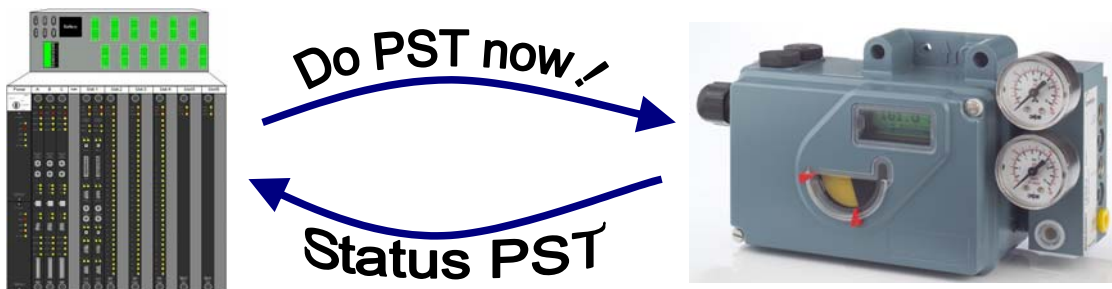

The communication protocol is used only to send information to a PC or a DCS in charge of the diagnostic and predictive maintenance.

Of course SRD991 and SRD960 for PST are compatible not only with Triconex but also with all other manufacturers of SIS Logic Solver.

Fail in Place (Full pressure maintained in output in the event of power / electronic failure)

This functionality is for customers that intend to use the positioner only for monitoring of the PST and not for shutdown application. Shutdown in such cases is initiated through a Solenoid Valve (SOV). With this functionality in either case i.e. supply by 20mA or no supply at all, the positioner will send full air supply to actuator and keep the valve open.

This type of application enables the highest availability of the final control element thereby reducing any spurious trips.

HART, Foundation Fieldbus H1, Profibus PA solutions

PST solutions are designed for HART, FOUNDATION Fieldbus H1 and PROFIBUS PA. All features like dedicated binary Input or Output, Soft PST are identical whatever the protocol of communication is. The DTM, the configuration, the diagnostic and the way of work are absolutely similar too.

HART cyclic PST feedback

In case of use of HART communication positioner can send the status of PST by mean of HART cyclic information. In such way the DCS is able to read out the PST independently of Instrument Asset Management System.

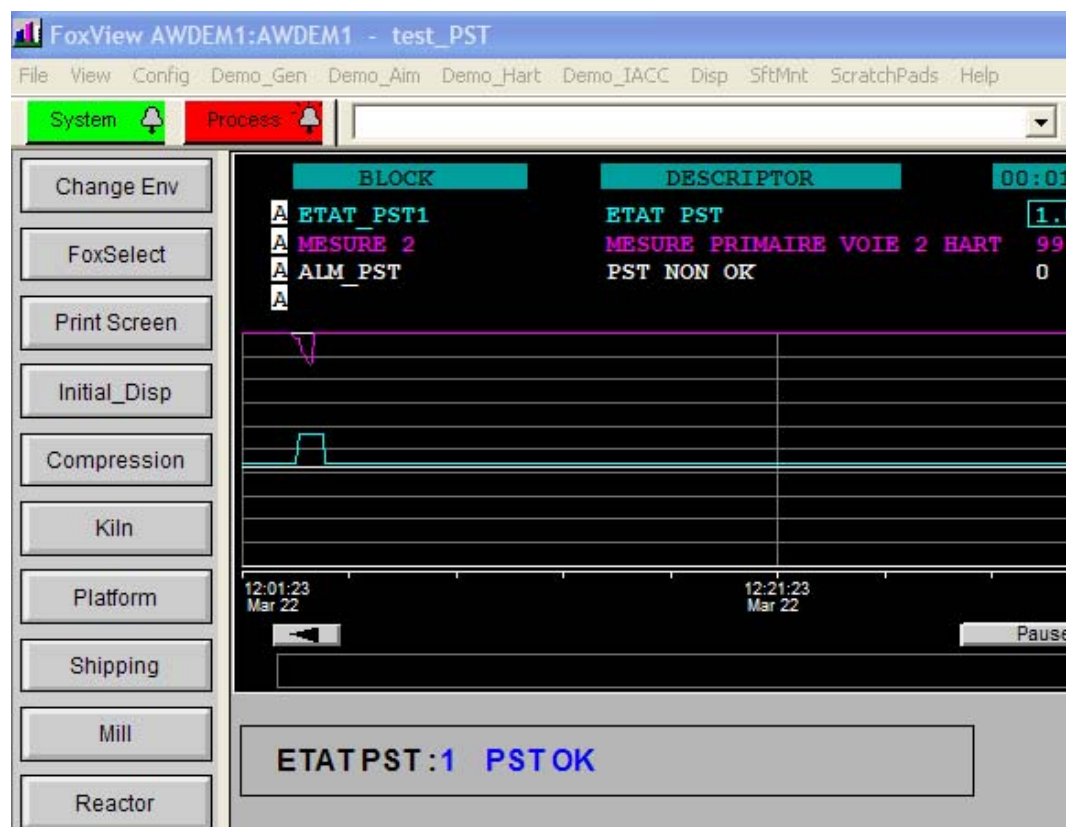

Active Monitoring of SOV (dip detection)

In case of use of a solenoid valve (SOV) to shutdown valve, positioner has the capability to monitor the precise status of SOV. This functionality also called dip detection, is monitoring the pressure drop after the SOV that occurs within an extremely short span of time. The positioner is able to detect any dip on the pressure generated by short impulse on the SOV.

Trigger capability (monitoring of FST in case of shut down)

This feature enables a registration of the characteristic of closing of the valve during plant shutdown. This feature provides useful insights into the behaviour of the final element.

Local Control Panel LCP960

A Local Control Panel certified ATEX II 2 G EEx d can be also used to do a local monitoring of the PST. A push buttons on the LCP activate the PST and the status of the PST can be read in clear through a backlight LCD.

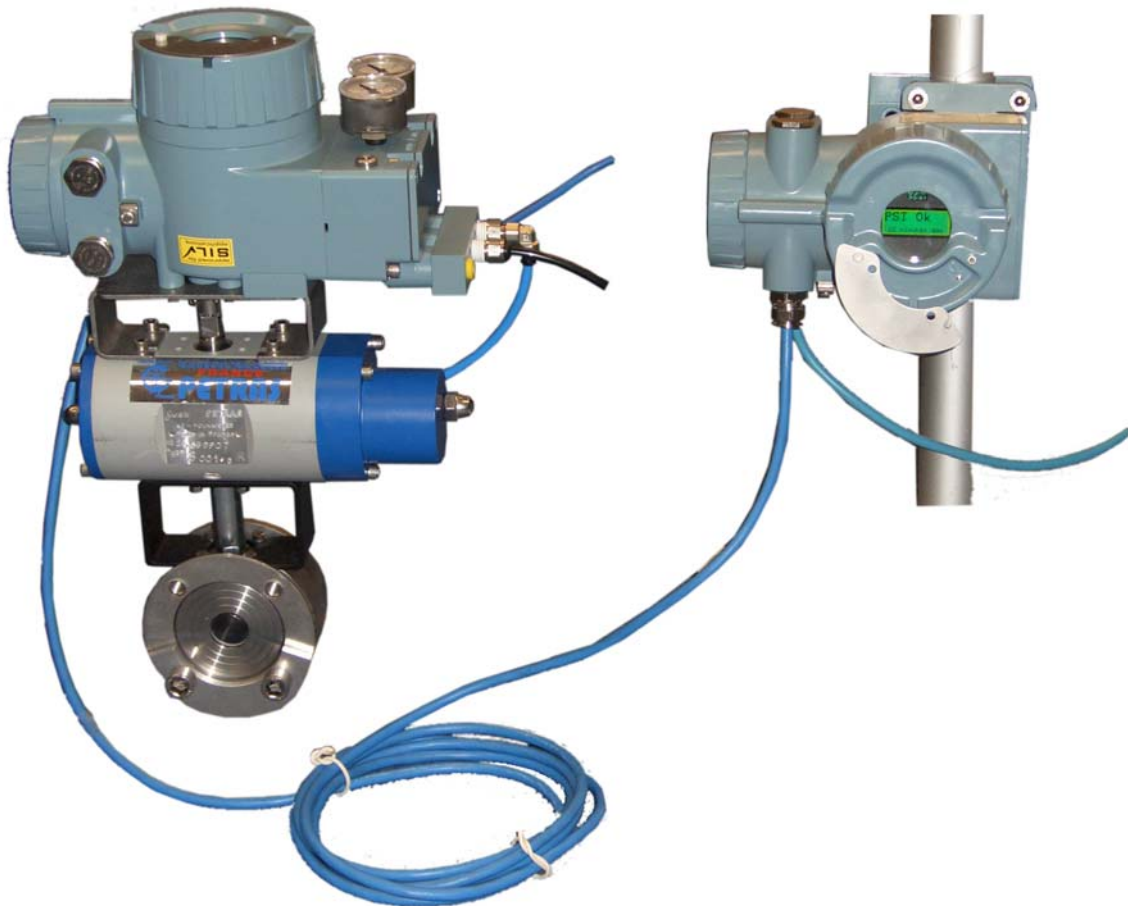

3 TYPICAL ARCHITECTURE:

Many different types of architecture are possible with our SRD960 and SRD991 to supervise the PST.

A typical architecture is hereby presented. Of course other architectures can be made, mixing other manufacturers of DCS or Logic Solver.

The eventual addition of a Solenoid Valve for the shut down, Push Button to activate PST, Lamp to signal the status of the PST is at the discretion of the end user.

Typical architecture (Logic Solver master of PST and Shut Down)

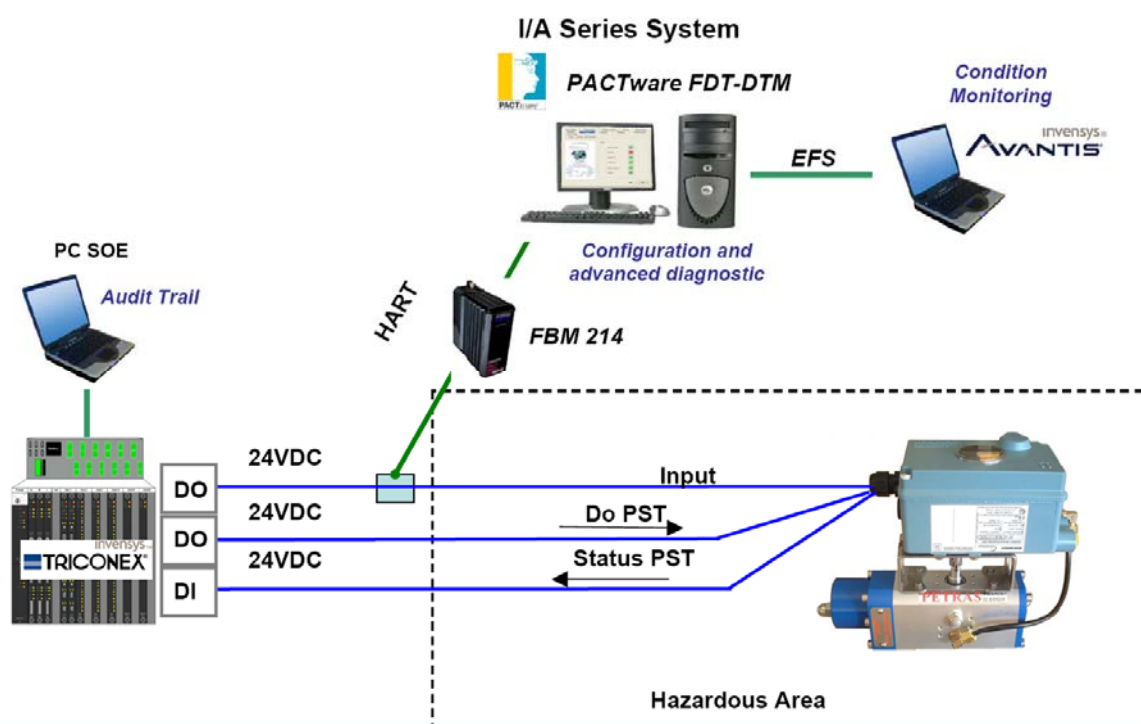

- SRD991 / SRD960 HART based solution. (identical solution if FoxCom communication). Notice that for the SRD991 (intrinsically safe) we recommend to use in combination with the SRD991 an Ex Isolation ATEX Barrier TV228.
- Positioner is used as a SOV. Positioner is certified up to SIL3 for shut down application
- The HART signal is read with a FBM214 in series in the Loop or by mean of HART Multiplexer.
- Condition Monitoring of Avantis is based on the precise device status of the positioner.
- PST can be executed automatically, on request through HART communication, or on Logic Solver request.
- Logic Solver knows the availability of valve for shut down.

Typical architecture 2 (Logic Solver master of PST and Shut Down +HART Multiplexer)

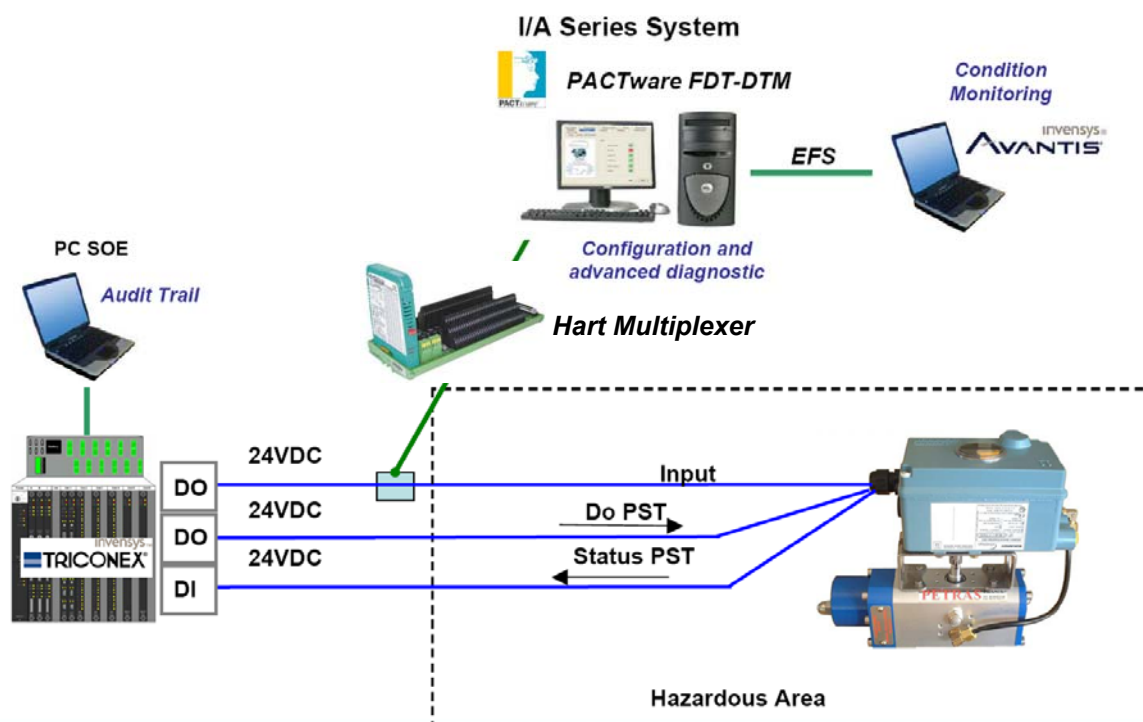

- SRD991 / SRD960 HART based solution. (identical solution if FoxCom communication). Notice that for the SRD991 (intrinsically safe) we recommend to use in combination with the SRD991 an Ex Isolation ATEX Barrier MT228.
- Positioner is used as a SOV. Positioner is certified up to SIL3 for shut down application
- The HART signal is read with a HART Multiplexer in the Loop or by mean of HART Multiplexer.
- Condition Monitoring of Avantis is based on the precise device status of the positioner.
- PST can be executed automatically, on request through HART communication, or on Logic Solver request.
- Logic Solver knows the availability of valve for shut down.

**Typical architecture 3 (LCP960 and SRD960 +HART Multiplexer)
Use of the Local Control Panel LCP960 in combination to SRD960**

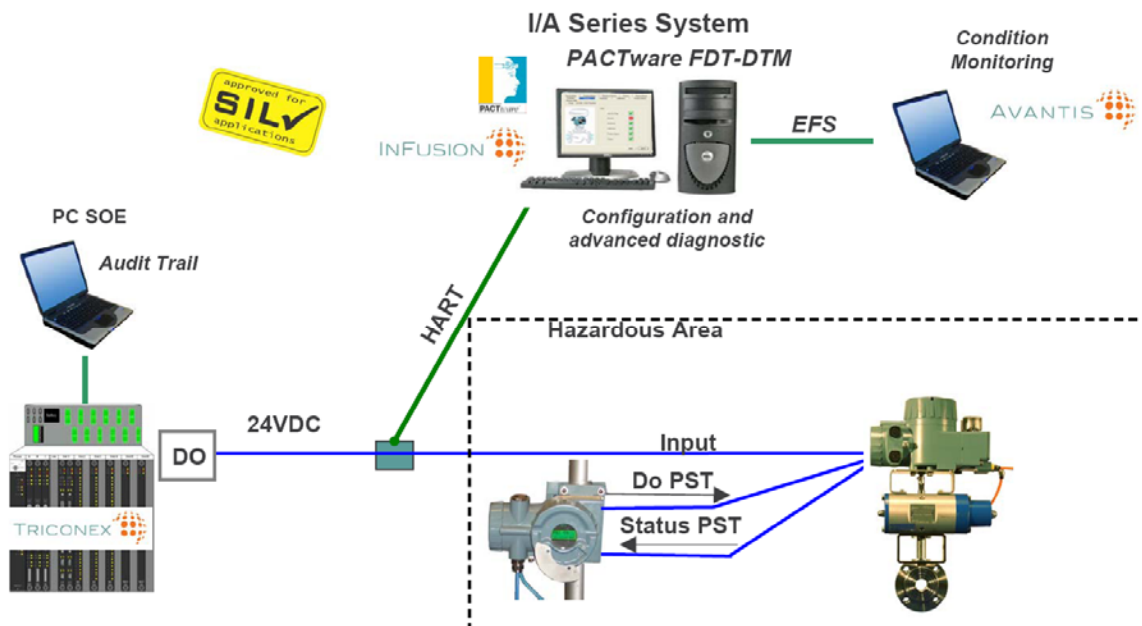

- SRD960 HART based solution. (identical solution if FoxCom communication).
- Positioner is used as a SOV. Positioner is certified up to SIL3 for shut down application
- The HART signal is read with a HART Multiplexer in the Loop or by mean of HART Multiplexer.
- Condition Monitoring of Avantis is based on the precise device status of the positioner.
- PST can be executed automatically, on request through HART communication, or on LCP960 request.
- LCP960 give the feedback of the PST Status as well as the timer (when was done last PST)
- LCP960 can be use with any SRD960 independently of the protocol of communication.
- Fully ATEX Ex d certified solution

Typical architecture 4 (SRD960 or SRD991 + SOV)
SRD positioner used only to monitor the PST, shutdown made by SOV

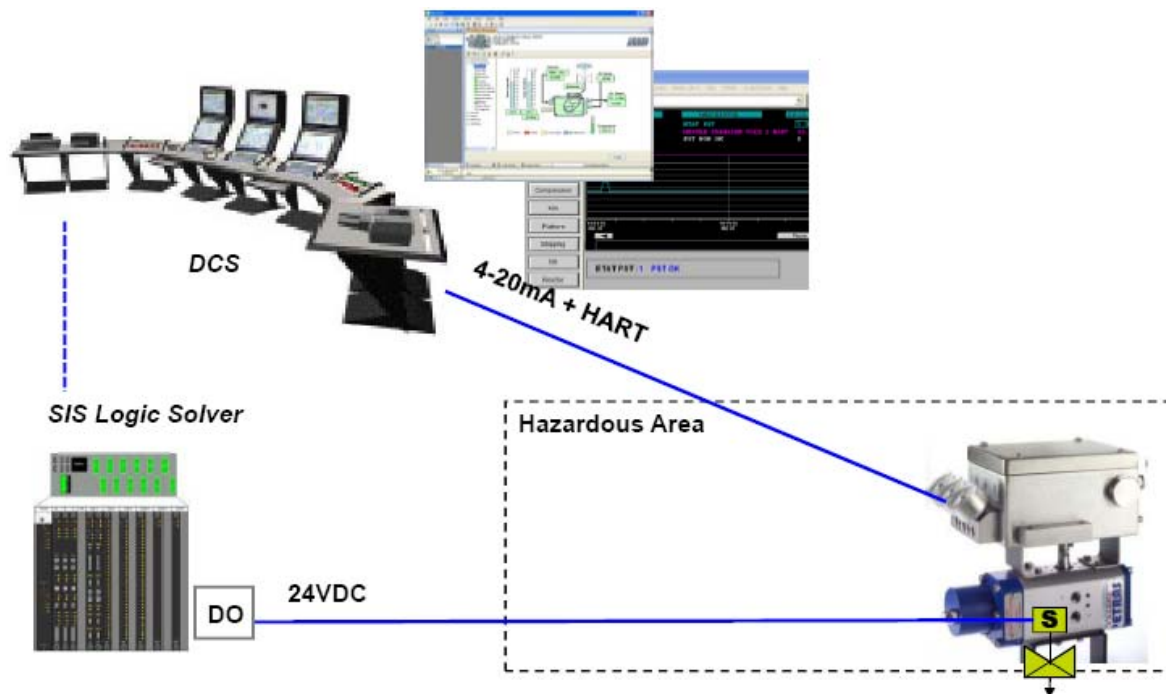

- SRD991 or SRD960 HART based solution with HART cyclic PST feedback
- Trigger capability (monitoring of FST in case of shut down)
- Fail in place
- Active Monitoring of SOV (dip detection)

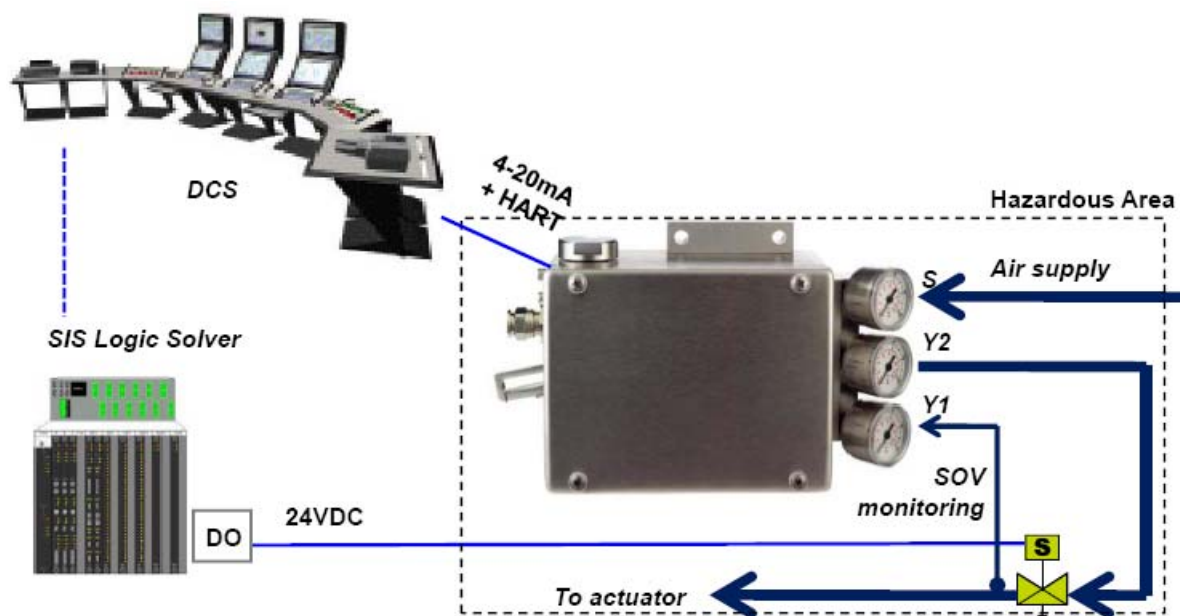

4 HOW TO ORDER

Please refer to respective PSS for entire choice of model.

Notice that the function of PST is required for this option:

Option	E for Binary input-output.
Additional Option	B for Pressure sensors for diagnostic.
Additional Option	E for design for ESD application

An example of the minimum model code is listed below:

Intelligent Positioner **SRD991-xxExxxxxNA-BEVxx** (Intrinsic safety application)

or

Intelligent Positioner Exd **SRD960-xxExxxxxxx-BE** (Explosion proof application)

LCP960 to be ordered like **SRD960-LXEDSxxxxFA-X**

Noticed that mechanical or inductive limit switches can be built-in also in the SRD991 (Intrinsic safety application).

5 SPECIFICATIONS OF PARTIAL STROKE TEST

PST made with intelligent positioners SRD991 for Intrinsically Safe application or SRD960 for Explosion Proof application with specific functionality of PST.

Supply 24VDC or 4-20mA.

Communication protocols HART, PROFIBUS PA, FOUNDATION Fieldbus H1.

Additional binary inputs and outputs for request PST from SIS logic solver and feedback status.

FDT-DTM software for configuration and advanced diagnostics

Activation of Test:

- Manually (locally on built-in push button with LCD display or through communication)
- Automatically
- Through a separate binary input for SIS logic solver
- LCP960 (Local Control Panel)

Testing Status (status read through communication)

- Not Done
- Running
- Restricted
- OK

Status PST available through digital outputs for SIS logic solver or external signalisation

HART cyclic PST feedback for DCS independently of Instrument Asset Management System

High Safety of the PST

- Maximum Wait Time [Seconds]
- Minimum Pressure [bar] Minimum pressure between 0 to 6 bars
- Soft PST [Seconds] Ramp freely configurable up to 100 s.

SIL (Safety Integrity Level)

SRD991 and SRD960 are suitable for use in a safety related application up to SIL 3 according to IEC 61511-1. Certificate released by Exida.

Request of PST from SIS logic solver and feedback are totally independent from the protocol of communication.

Environment Integration:

- Full integration into IA Series System (FBM214 for HART communication) and Avantis CM.
- Full integration into any other DCS that support FDT-DTM standard.
- Full integration with Triconex SIS logic solver (Tricon and Trident).
- Full integration with any other SIS logic solver.
- Full integration with any HART multiplexer and DCS or stand alone PC network.

SRD991 and SRD960 can be mounted easily onto any ESD (Emergency Shut Down) or ESV (Emergency Shut Vent) valves. A wide range of mounting kits is available for that.

LCD Display on SRD991 and SRD960 with full text in many different languages and push buttons for an easy configuration and diagnostic on board.

Rugged aluminium casing with show window for LCD display or SST 316 housing on option

Additional built-in inductive or mechanical limit switches for SRD991.

Predictive Maintenance : Break Pressure Trend / Re-Inflate Time Trend / PST Signature

Complete PST report with all diagnostics for print out (by means of FDT-DTM).

PST for single or double acting

Fail in Place (Full pressure in Output in any case) or Fail Safe (Depressurized Output in case of Fail)

Active Monitoring of SOV (dip detection)

Trigger capability (monitoring of FST in case of shut down)

Additional Documentation for these products:**Technical Information for Attachment Kits for Positioners**

TI EVE0011 A Overview of Attachment Kits of all positioners on actuators/valves of different manufacturers

Technical Information for commissioning of PST positioners

TI EVE0205 PST How to set up the Partial Stroke Testing for SRD991 and SRD960

SRD991**Quick Guide:**

QG EVE0105 A/B Extract of Master Instruction for an easy to use, understand, and fast start-up guide. This document highlights the most important benefits.

Product Specification Sheet:

PSS EVE0105 E SRD991 -all versions-

Master Instructions:

MI EVE0105 E SRD991 -all versions-

SRD960**Quick Guide:**

QG EVE0109 A Extract of Master Instruction for an easy to use, understand and fast start-up guide. This document highlights the most important benefits.

Product Specification Sheet:

PSS EVE0109 A SRD960 -all versions-

Master Instructions:

MI EVE0109 A SRD960 -all versions-

SRD991 and SRD960**Technical Information for Fieldbus-Communication:**

TI EVE0105 P SRD991/960 -PROFIBUS-PA

TI EVE0105 Q SRD991/960 -FOUNDATION Fieldbus H1

Instruction for HART-Communication:

MI EVE0105 B HART with Hand-Held Terminal

FOXBORO ECKARDT GmbH
Pragstrasse 82
D-70376 Stuttgart
Germany
Tel. + 49(0)711 502-0
Fax + 49(0)711 502-597

invensys

DOKT

<http://www.foxboro-eckardt.eu>
<http://www.foxboro-eckardt.de>
<http://www.foxboro.com/instrumentation/>

ECKARDT S.A.S.
20 rue de la Marne
F-68360 Soultz
France
Tel. + 33 (0)3 89 62 15 30
Fax + 33 (0)3 89 62 14 85