

Model 871DO-C
Dissolved Oxygen Sensors and Sensor Accessories

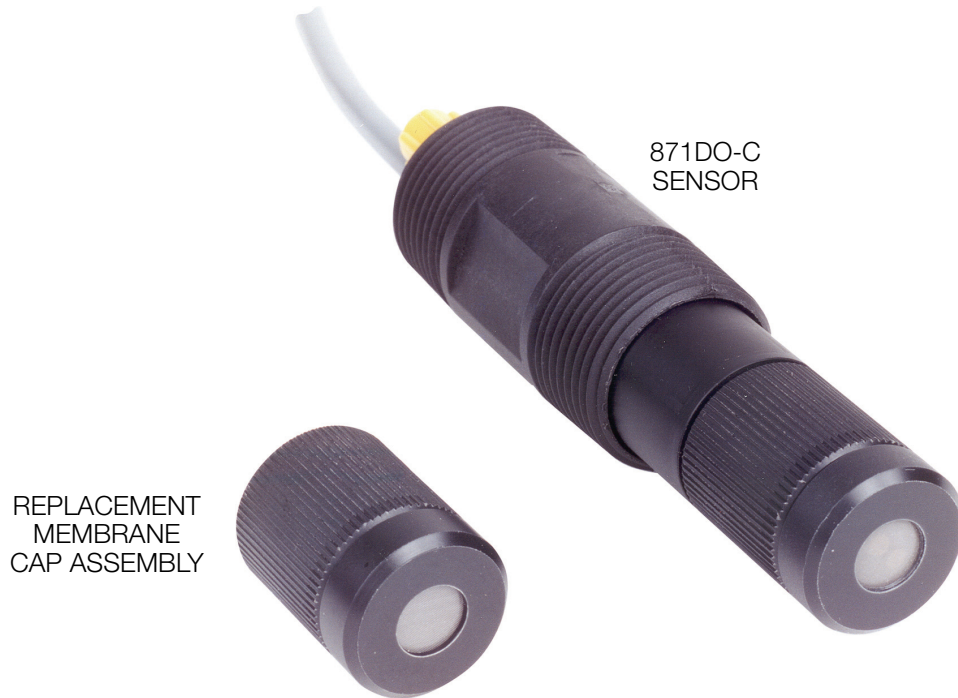

The Foxboro® brand Model 871DO-C Sensor is available from Invensys PProcess Systems (IPS). This sensor, when used in conjunction with 871DO-C Sensor Accessories and the 873DO Electrochemical Analyzer, provides a reliable and accurate measurement of dissolved oxygen in aqueous streams, ponds, and industrial processes. As symbolized by the "CE" marking, these sensors conform to the applicable European Union Directives.

GENERAL DESCRIPTION

The 871DO-C Sensor measures dissolved oxygen by using a 3-electrode cell and the Clark Polarographic Method. A fourth electrode is used for sensor diagnostics. The cell electrodes, contained within an electrolyte, are isolated from the process medium by an extremely durable, oxygen-permeable, composite membrane made of tetrafluoroethylene (tfe) and dimethylsilicone rubber. This composite membrane is reinforced with a stainless steel mesh. A fixed potential is maintained between the gold working

cathode and the silver/silver chloride (Ag/AgCl) reference electrode. Dissolved oxygen in the process solution permeates the composite membrane and is electrochemically reduced at the cathode. This electrochemical reaction produces a small current that is proportional to the concentration of dissolved oxygen in the process solution. A gold test electrode within the sensor enables diagnostic performance testing.



MOUNTING FLEXIBILITY

The 871DO-C Sensor is designed with 1-inch external NPT connections on both the upper and lower portions of the sensor body. The sensor can be installed in tank walls and process lines by using the 1-inch NPT connection on the lower body, or by mating it to a hex-head bushing or tee. Ball valve assemblies allow insertion and removal of the sensor from the process without interruption of the process.

For submersible applications, the 1-inch external NPT connection on the cable end of the sensor can be coupled to a length of user-supplied 1-inch pipe, and the sensor body submersed in an open vessel with or without a ball float accessory.

For insertion of the sensor into aeration basins, stainless steel rail mounting hardware is offered as described and shown in the ACCESSORIES section.

SENSOR DIAGNOSTICS

When used with the 873DO Electrochemical Dissolved Oxygen Analyzer, the 871DO-C Dissolved Oxygen Sensor offers several diagnostic features as follows:

- ▶ Membrane Breakage
- ▶ Membrane Fouling
- ▶ Electrolyte Bubble Detection.

Membrane breakage diagnostics provide a local signal if the oxygen permeable membrane has been torn, punctured, or otherwise damaged, or if the process solution should contaminate the electrolyte.

Membrane fouling diagnostics monitor degradation of oxygen permeation rate caused by fouling of the membrane.

Finally, the third diagnostic, electrolyte bubble detection, will detect a bubble in the internal electrolyte or excess buildup of silver chloride (AgCl) on the auxiliary electrode. This diagnostic feature also warns of the loss of internal filling solution.

The diagnostic features above alert the user of common sensor maladies that affect the reliability of the dissolved oxygen measurement.

AIR CALIBRATION

The 871DO-C Sensor is simple to calibrate. By placing the sensor in ambient air, which has a known concentration of oxygen, users can calibrate the sensor quickly and easily.

RUGGED MEMBRANE FOR EXTENDED LIFETIME

A reinforced composite membrane is utilized on the 871DO-C Sensor. This composite membrane technology greatly enhances the stability and response time of the measurement.

EASILY REPLACEABLE MEMBRANE CAP ASSEMBLY

Replacing the membrane cap assembly is simple and requires no tools. Replacement membranes are incorporated in a knurled cap assembly that can be easily removed for quick service in the field. The 871DO-C Sensors are supplied with one replacement membrane assembly, and a bottle of electrolyte for refilling. Refer to the ACCESSORIES section for membrane replacement kits.

INTEGRAL TEMPERATURE MEASUREMENT

Automatic Temperature Compensation (ATC) is a standard feature in the 873DO Electrochemical Analyzer when used with an 871DO-C Sensor. ATC is achieved by an accurate measurement of process temperature with a 100 k Ω thermistor contained within the sensor. The dissolved oxygen measurement can then be temperature compensated by the analyzer over a range of 0 to 50°C (32 to 122°F).

OPTIONAL ELECTRODE CLEANING SYSTEM

An electrode cleaning system (ECS) is available as an accessory for use with the 871DO-C Sensor. The ECS reduces the fouling of the composite membrane and removes fouling material by continuously wiping the membrane surface. Using the ECS reduces the need for manual cleaning. It is best used in quiescent applications such as fish farming to minimize algae growth.

ECS Cleaners are not recommended for processes that contain suspended abrasive materials which can damage the composite membrane. Refer to PSS 6-1A2 C and to the ACCESSORIES section.

STANDARD SPECIFICATIONS

Process Pressure and Temperature Limits

0 and 210 kPa gauge (0 and 30 psig)
0 and 50°C (32 and 122°F)

Storage Limits

0 and 55°C (32 and 131°F)

Linearity

Better than $\pm 1\%$ of span at constant temperature

Repeatability

$\pm 2\%$ of span

Drift

Less than $\pm 1\%$ of measurement span per day in nonmembrane fouling conditions

Response Time

DISSOLVED OXYGEN CONCENTRATION

Nominal 90% of step response in less than one minute at 25°C (77°F).

TEMPERATURE

Nominal 90% of step response in less than 10 minutes within an operating range of 0 to 50°C (32 to 122°F).

Minimum Flow Rate (Recommended)

IN TEES, TANKS, AND WEIRS

Linear flow should be 2 to 4 meters/minute (6.5 to 13.1 feet/minute)

IN A FLOW CELL

Volumetric flow should be 1 to 1.5 liters/minute (0.26 to 0.4 U.S. gpm)

Automatic Temperature Compensation (ATC)

Achieved using 100 k Ω thermistor within sensor to provide ATC between 0 and 50°C (32 and 122°F).

Sensor Type

Polarographic Clark Cell with a composite membrane enclosing four electrodes in potassium chloride (KCl) electrolyte.

Sensor Membrane

Stainless Steel Reinforced Composite Membrane on a Replaceable Cap

Sensor Tip Immersion

25 mm (1 in) minimum; 21 m (70 ft) maximum

Sensor Mounting

1-in external NPT on both ends, with a 1.125-in wrench flat on body. For in-situ or in-line mounting, as required. In-situ mounting via user-supplied pipe sealed to sensor allows mounting in either closed, pressurized vessels; or in open, unpressurized vessels, tanks, troughs, and the like. See DIMENSIONS - NOMINAL section.

Process Wetted Parts Materials

BODY

PVDF (upper housing) and
Noryl (lower housing)

MEMBRANE

Silicone Rubber

MEMBRANE CAP HOLDER

Noryl

O-RINGS

Silicone Rubber, Viton, and EPR

VENT CAP

Acetal

VENT SEAL GASKET

Silicone Rubber

STANDARD SPECIFICATIONS (CONT.)

Measuring Electrode

Gold

Reference Electrode

Silver/Silver Chloride (Ag/AgCl)

Auxiliary (Anode) Electrode

Silver

Test Electrode

Gold

ElectroMagnetic Compatibility (EMC)

The 871DO-C Sensor, when its cable is connected through rigid metal conduit as recommended for the Foxboro Models 873DO Electrochemical Analyzers (220 V ac, 240 V ac and Metal Enclosures only), complies with the requirements of the European EMC Directive 89/336/EEC.

Integral Cable Terminations - See Model Code

NONCONNECTOR TERMINATIONS

Seven wires, stripped and tinned, #22 AWG - Optional Selection "-3"

TERMINATIONS WITH CONNECTOR

Electrode connector (plug) to mate with patch cable from 873DO Analyzer - Optional Selections "-5" or "-7"

Cable Length - See Model Code

INTEGRAL CABLE PLUS EXTENSION, MAXIMUM

150 m (500 ft) - Optional Selection "-3"

INTEGRAL CABLE, MAXIMUM

150 m (500 ft) - Optional Selection "-5"

INTEGRAL CABLE, STANDARD

9 m (30 ft) - Optional Selection "-7"

Approximate Mass

0.35 kg (0.75 lb) - Includes 9 m (30 ft) Cable

Nominal Dimensions

See DIMENSIONS - NOMINAL section.

ACCESSORIES

Rail Mounting Kit

Mounting kit includes stainless steel rail mounting hardware for use with customer supplied 1-inch pipe for sensor insertion into aeration basins. (Refer to Figure 1 and Table 1.)

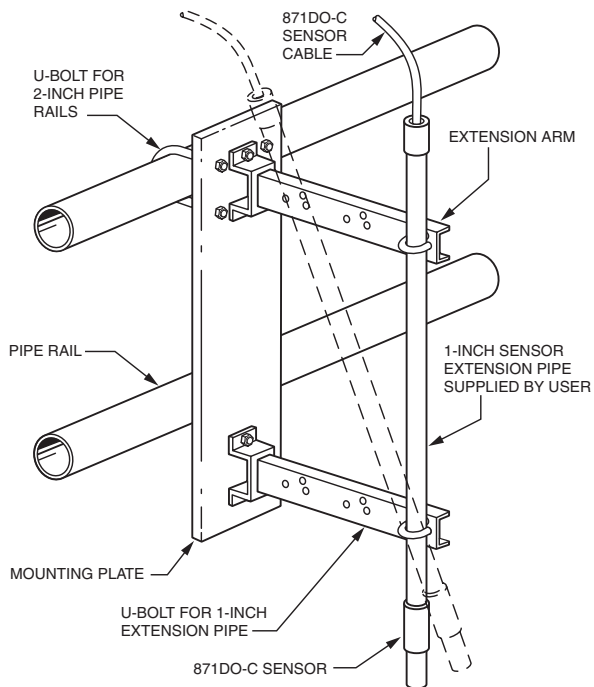

Figure 1. 871DO-C Sensor Shown Assembled to Rail Mounting Kit

Table 1. Rail Mounting Kit

Description	Qty.	Foxboro Part No.
Rail Mounting Kit	1	BS806KN
Contents of Kit		
U-Bolt for 1-in Pipe	2	BS806VR
U-Bolt for 2-in Rail	2	BS806VS
Mounting Plate	1	BS806ND
Extension Arm	2	BS806NC
Hex Bolt, ss, 0.312-18 x 0.75	4	X0137BF
Nut, 0.312-18, ss	16	X0142BW
Washer, Plain, 0.312, ss	16	X0143AZ
Washer, Lock, 0.312, ss	16	A2015AB

ACCESSORIES- (CONT.)

Bushings

Bushings are used to mount sensors in a system that has process piping larger than the 1-in external NPT connection of the sensor. Bushings are offered with 1 1/4-in or 1 1/2-in external NPT connections, and are available in either 316 ss, PVDF, or CPVC. Refer to Figure 2, and to Table 2 for Bushing specifications. Also see Dimensions – Nominal section for bushing dimensions.

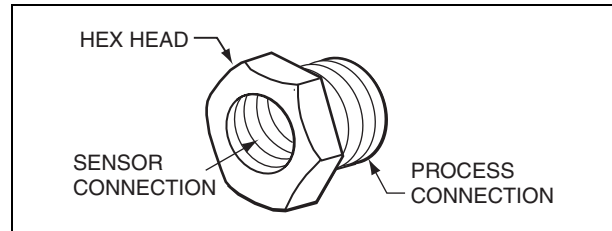

Figure 2. Typical Bushing

Table 2. Bushing Specifications

Bushing Material	Press-Temp Rating	Sensor Connection	Process Connection	Foxboro Part Number
316 ss	Note ^(a)	1 NPT	1 1/4 NPT 1 1/2 NPT	BS805TD BS805TF
PVDF ^(b)	Note ^(a)	1 NPT	1 1/2 NPT	BS805TG
CPVC ^(b)	Note ^(a)	1 NPT	1 1/4 NPT 1 1/2 NPT	BS805TE BS805TH

(a) Bushing meets the pressure-temperature limits listed in Standard Specifications section.

(b) PVDF = polyvinylidene fluoride
 CPVC = Chlorinated polyvinyl chloride

ACCESSORIES- (CONT.)

Ball Valve Assemblies

The ball valve assembly permits an 871DO-C Sensor to be inserted and removed from a process stream or tank under rated temperature and pressure without draining the system, or resorting to a bypass arrangement. A ball valve assembly consists of the ball valve unit and an insertion shaft assembly; both support a sensor in a stream. A standard flexible conduit (user provided) can be used for cable protection. Also refer to Figure 3, and to Table 3 for Ball Valve Assembly specifications. Also see Dimensions – Nominal section for ball valve dimensions.

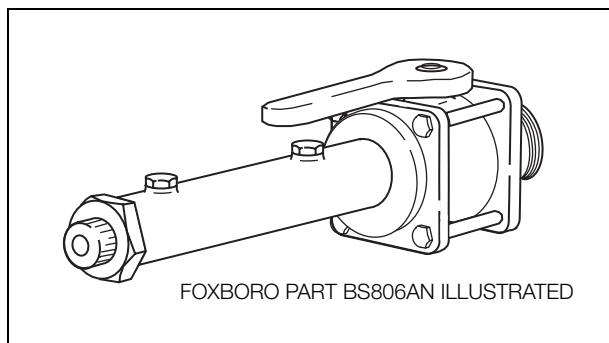

Figure 3. Purgeable Ball Valve Assembly

Table 3. Ball Valve Assembly Specifications

Materials of Process Wetted Parts ^(a)				Rated Pressure		Max. Temp. at Rated Pressure		Process Line Connection	Foxboro Part Number
Process Connection and Housing	Ball Seat	Ball Valve	O-Ring	kPa	psi	°C	°F		
				316 ss	ptfe	Glass-Filled Polypropylene	EPR	1000	145
400	55	65	150						
70	10	88	190						
Titanium	ptfe	Kynar	EPR	1600	230	20	68	1 1/2 NPT	BS806EP
				1000	145	60	140		
				350	50	140	284		

(a) Contact IPS for other materials.

ACCESSORIES (CONT.)

Tee Assemblies

Tees are used for flow-through installations in a pipeline. The sensor connection end and process inlet and outlet ports have internally threaded ends for the 316 ss and PVDF Tee materials, and internal pipe socket weld connections for the CPVC Tee material. Reducing bushings are used on the sensor end, and also the process ends (as required) to accommodate the 1-inch NPT sensor and various process connection sizes. Refer to Figure 4, and to Table 4 for Tee Assembly specifications. Also see Dimensions – Nominal section for tee dimensions.

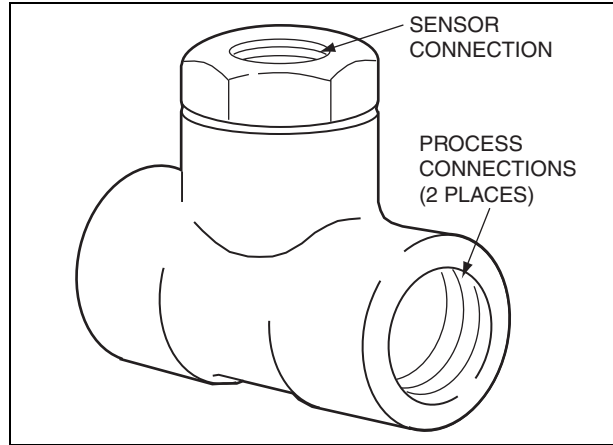

Figure 4. Tee Assemblies

Table 4. Tee Assembly Specifications

Tee Assembly Material	Press-Temp Rating	Sensor Connection ^(a)	Process Connections ^(b)	Foxboro Part Number
316 ss	Note ^(c)	1 NPT	1 NPT 1 1/4 NPT 1 1/2 NPT	BS805SV BS805SY BS805TA
PVDF	Note ^(c)	1 NPT	1 NPT 1 1/2 NPT	BS805SW BS805TB
CPVC	Note ^(c)	1 NPT	33 mm (1.3 in) I.D. ^(d) 41 mm (1.6 in) I.D. ^(d) 48 mm (1.9 in) I.D. ^(d)	BS805SX BS805SZ BS805TC

(a) Reducing bushing is used to accommodate a 1 NPT sensor connection.

(b) Reducing bushings are used as required to accommodate the process connections listed in the table.

(c) Tee meets pressure-temperature limits listed in Standard Specifications section.

(d) Pipe socket-weld.

ACCESSORIES (CONT.)

Electrode Protection Sleeve

The electrode protection sleeve protects the membrane from contacting the bottom or side of a tank. This PVDF sleeve is applicable to submersible applications, and is usable within the pressure-temperature limits listed in the Standard Specification section. Specify Foxboro Part Number BS807RW. Also see Dimensions – Nominal section for sleeve dimensions.

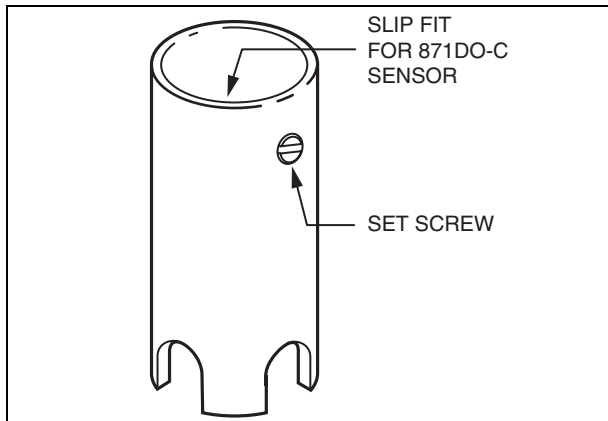

Figure 5. Electrode Protection Sleeve

Junction Box

The junction box shown in Figure 6 provides an interface for connecting the 7-conductor sensor assembly cable or patch cord to an extension cable (see Patch Cord and Extension Cable sections that follow). These junction boxes are weatherproof and dusttight as defined by IEC IP65 and provide the watertight protection of NEMA Type 4. Specify Foxboro Part Number 0051052.

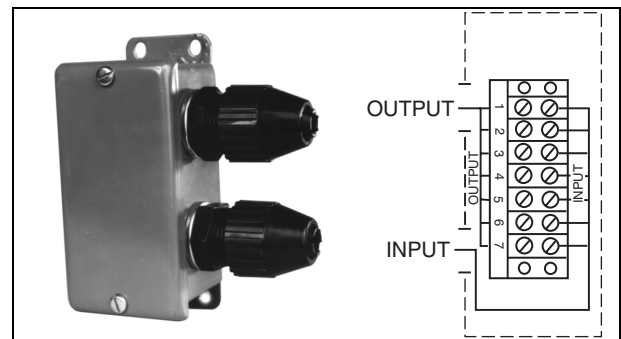

Figure 6. Junction Box

ACCESSORIES (CONT.)

Patch Cords

Patch Cords are 7-conductor cables that provide connections between sensors, with Optional Cable Selection Codes -5 or -7, and junction box. There is a socket on one end, and nonterminated leads (stripped and tinned only) on the other end. See Table 5 and Figure 7.

Table 5. Patch Cord Part Numbers

Option Code	Cable Length	Part Number
-5 or -7	10 ft (3 m) ^(a)	BS806JY
-5 or -7	See Note ^(b)	BS806JT ^(b)

- (a) Cable length tolerance is +1, -0 ft (+0.3, -0 m).
- (b) Nonstandard cable length per sales order up to 500 ft (150 m). Specify part number and cable length.

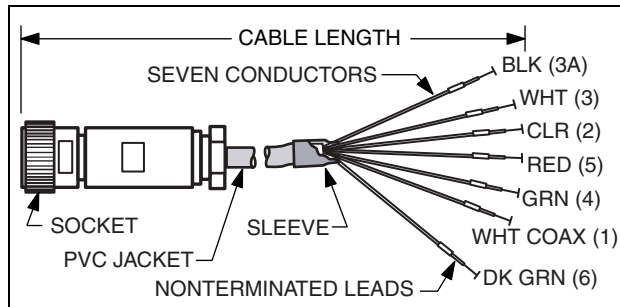

Figure 7. Patch Cord

Extension Cable

This extension cable with seven conductors provides connections between the junction box and the electrochemical analyzer. Cable is neither dressed nor provided with terminal connections. The user can make his own cable assembly to the desired length and terminations required, with the restriction that the maximum separation between the 871DO-C Sensor and the 873DO Analyzer is 500 ft (150 m). The cable has an outer jacket of PVC, and is rated at 50°C (122°F) with a maximum allowable current of 2 A. Offered in spools per sales order up to a maximum length of 1000 ft (300 m). Specify Foxboro Part Number P0170UU and length required in feet or meters.

Cell Simulator

The 870DO-C Cell Simulator, shown in Figure 8, plugs into either of the two patch cords (BS806JY or BS806JT) described previously. This device is used to simulate the presence of an 871DO-C sensor in order to verify the functionality of an 873DO Electrochemical Analyzer and a patch cord. The simulator is approximately 2 in (51 mm) long and less than 7/8 in (22 mm) in diameter. Specify Foxboro Part Number BS806KM.

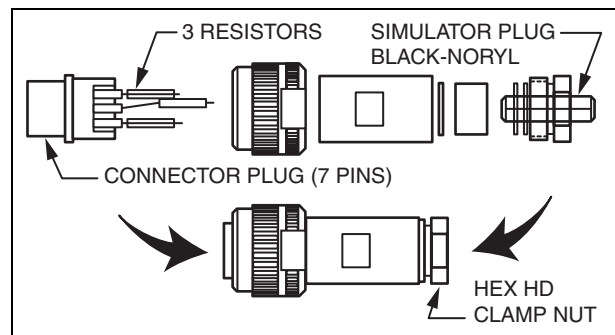

Figure 8. Cell Simulator

ACCESSORIES - (CONT.)

Ball Float Assembly

The ball float assembly is a flotation device used for mounting sensors. It positions the sensor optimally so that the wave action over the ball “cleans” the membrane surface continuously, or promotes self-cleaning of the membrane with no mechanical parts to wear out. The “wave” action over the exposed sensor impacts the automatic self-cleaning of the sensor membrane. By using the ball float assembly, sensor maintenance is reduced by simply keeping the sensing surface cleaner for a longer period of time. The Ball Float Assembly is comprised of an 11-inch (280 mm) high density polystyrene ball float, a PVC spacer, and a 1-piece assembly comprising a 45° angled PVC elbow, and a lock down cap with threaded coupling to allow interconnection of the ball float to a user-supplied 1 NPT pipe. The 3-piece ball float assembly design ensures ease of installation and optimum sensor positioning; it holds the sensor at an insertion depth of approximately 4 1/4 inches (108 mm). Refer to Figure 9 and DIMENSIONS - NOMINAL section. Specify Foxboro Part Number BS808NT.

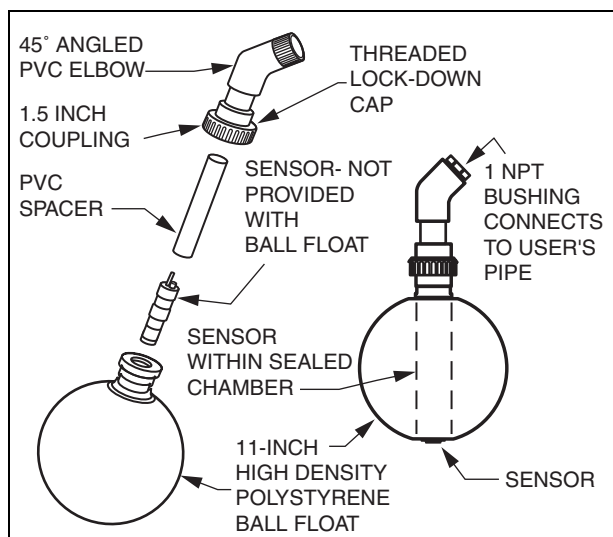

Figure 9. Ball Float Assembly
Membrane Replacement Kits
for 871DO-C Probes

IPS offers kits for membrane replacement. The kits may be ordered for a single membrane replacement, or the replacement of three membranes. Refer to Table 6.

Table 6. Membrane Replacement Kits

Single Membrane Kit ^(a)	Foxboro Part No.
1 50 ml Bottle Electrolyte with MSDS ^(b) 1 Vent Cap 1 Polishing Disc 1 Membrane Cap Assembly 1 Membrane Protection Cap 2 Silicone O-rings 1 Fill Instructions	BS807RU
Three Membrane Kit ^(c)	Foxboro Part No.
3 50 ml Bottles Electrolyte with MSDS ^(b) 3 Vent Caps 3 Polishing Discs 3 Membrane Cap Assemblies 3 Membrane Protection Caps 6 Silicone O-rings 1 Fill Instructions	BS807RV

- (a) Contains parts for single membrane replacement.
- (b) Material Safety Data Sheet.
- (c) Contains parts for three membrane replacements.

Electrode Cleaning System

The Foxboro Model ECS Electrode Cleaning system comprises a family of automatic in-line electrode cleaners used exclusively with many Foxboro pH, ORP, and the 871DO-C sensor. The continuous rotation of the cleaning element across the measuring element(s) minimizes or totally eliminates physical coatings that interfere with obtaining accurate measurements. The Model ECS is offered in various flow-through and submersible assembly configurations. The submersible version is used with the 871DO dissolved oxygen sensor in quiescent applications, such as fish farming, to minimize algae growth. Refer to PSS 6-1A2 C for configurations available, specifications, and ordering instructions.

MODEL CODE

Description	Model
Dissolved Oxygen Sensor	871DO
Membrane	
Composite Membrane	-C
Optional Selections	
Integral Cable, nonstandard length, with seven wires stripped and tinned; Specify length required, not to exceed 150 m (500 ft)	-3
Integral Cable, nonstandard length, terminated in connector plug; Specify length required, not to exceed 150 m (500 ft) ^(a)	-5
Integral Cable, standard length, terminated in connector plug Standard length of 9 m (30 ft) ^(a)	-7
Examples: 871DO-C-7 871DO-C-5: 25 m (82 ft) Cable Length	

(a) Optional selections -5 and -7 require a patch cord for mating to 873DO Analyzer. Refer to ACCESSORIES section.

DIMENSIONS - NOMINAL

**mm
in**

871DO-C SENSOR

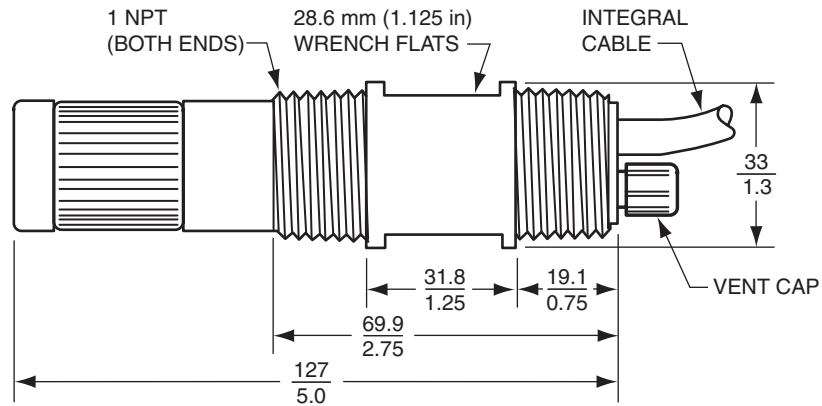

TEE ASSEMBLIES (INCLUDES REDUCING BUSHINGS)

316ss AND PVDF TEE ASSEMBLY

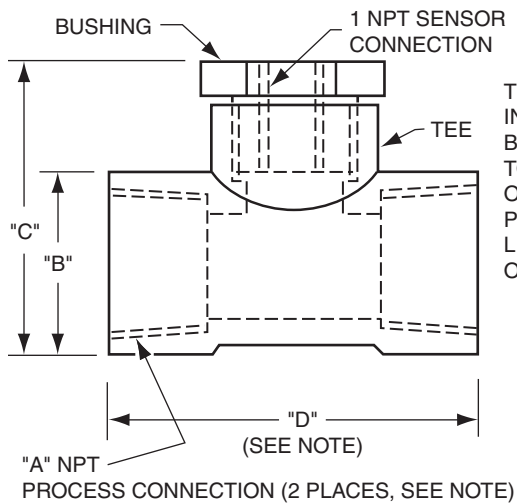

NOTE

THE "D" DIMENSION INCLUDES REDUCING BUSHINGS, IF REQUIRED, TO PROVIDE THE "A" NPT OR "A" DIAMETER PROCESS CONNECTION LISTED IN THE TABLES ON THE NEXT PAGE.

CPVC TEE ASSEMBLY

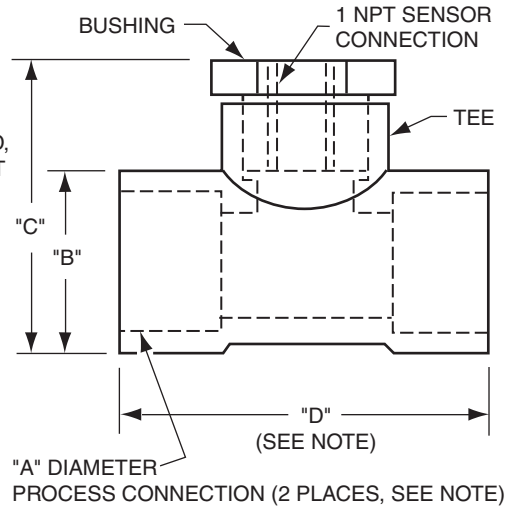

DIMENSIONS - NOMINAL (CONT.)

316 ss and PVDF Tee Assemblies

Part Number	Material	Dimensions ^(a)			
		"A"	"B"	"C"	"D"
BS805SV	316 ss	1 NPT	$\frac{64}{2.5}$	$\frac{94}{3.7}$	$\frac{124}{4.9}$
BS805SW	PVDF	1 NPT	$\frac{64}{2.5}$	$\frac{89}{3.5}$	$\frac{147}{5.8}$
BS805SY	316 ss	1 1/4 NPT	$\frac{64}{2.5}$	$\frac{94}{3.7}$	$\frac{124}{4.9}$
BS805TA	316 SS	1 1/2 NPT	$\frac{64}{2.5}$	$\frac{94}{3.7}$	$\frac{99}{3.9}$
BS805TB	PVDF	1 1/2 NPT	$\frac{64}{2.5}$	$\frac{89}{3.5}$	$\frac{122}{4.8}$

(a) The "B", "C", and "D" dimensions listed are approximate.

CPVC Tee Assemblies

Part Number	Material	Dimensions ^(a)			
		"A"	"B"	"C"	"D"
BS805SX	CPVC	$\frac{33}{1.3}$	$\frac{64}{2.5}$	$\frac{102}{4.0}$	$\frac{193}{7.6}$
BS805SZ	CPVC	$\frac{41}{1.6}$	$\frac{64}{2.5}$	$\frac{102}{4.0}$	$\frac{137}{5.4}$
BS805TC	CPVC	$\frac{48}{1.9}$	$\frac{64}{2.5}$	$\frac{102}{4.0}$	$\frac{124}{4.9}$

(a) The "B", "C", and "D" dimensions listed are approximate.

DIMENSIONS - NOMINAL (CONT.)

mm
in

BALL VALVE ASSEMBLY WITH 316 ss PROCESS CONNECTION AND PURGEABLE HOUSING
PART NUMBER BS806AN

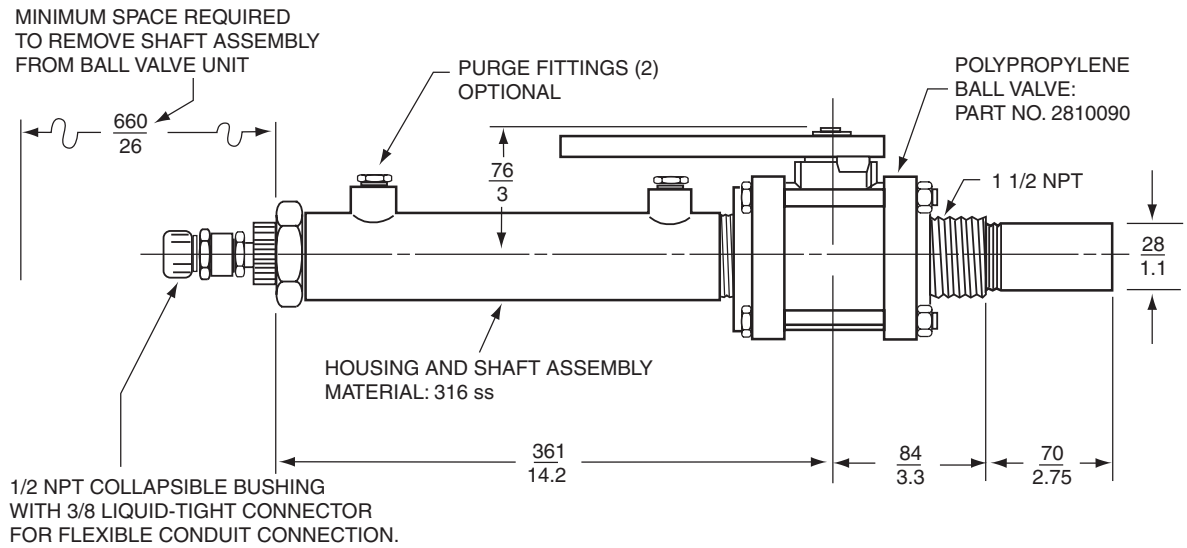

BALL VALVE ASSEMBLY WITH TITANIUM PROCESS CONNECTION AND PURGEABLE HOUSING
PART NUMBER BS806EP

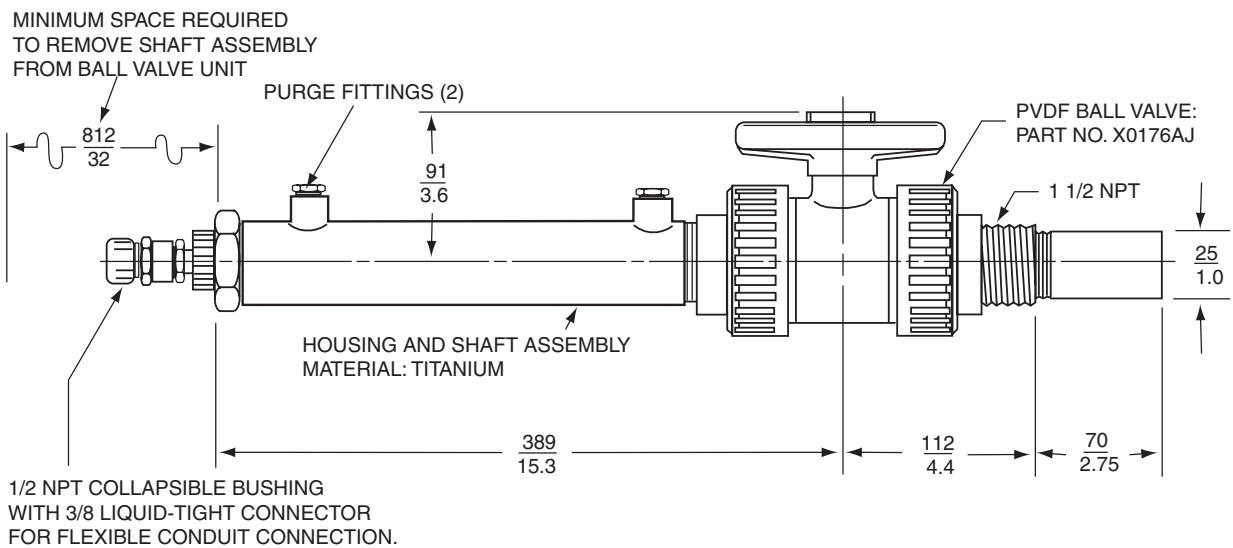

DIMENSIONS - NOMINAL (CONT.)

**mm
in**

BUSHINGS

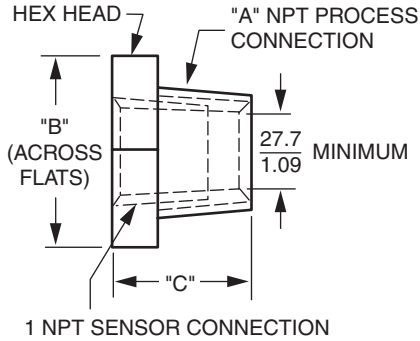

Part Number	Material	Dimensions(a)		
		"A"	"B"	"C"
BS805TD	316 ss	1 1/4 NPT	46 48	30 32
BS805TE	CPVC	1 1/4 NPT	46 56	30 34
BS805TF	316 ss	1 1/2 NPT	50 50	36 36
BS805TG	PVDF	1 1/2 NPT	50 50	36 36
BS805TH	CPVC	1 1/2 NPT	50 20	36 1.4

(a) The "B" and "C" dimensions listed are approximate.

ELECTRODE PROTECTION SLEEVE

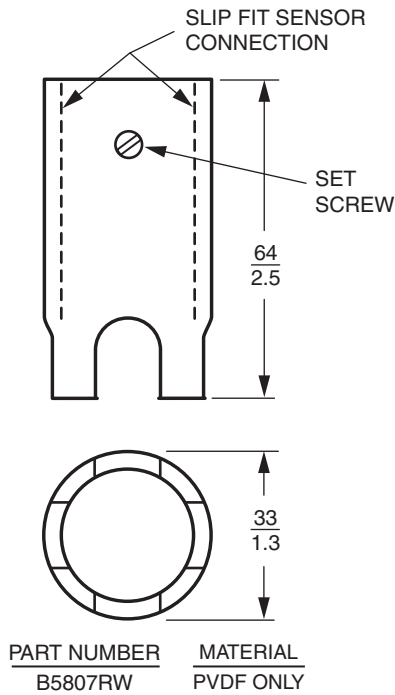

BALL FLOAT ASSEMBLY

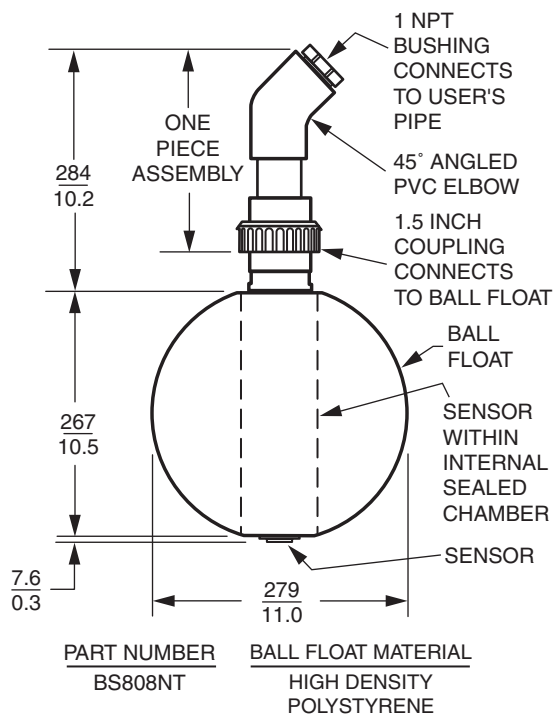

ORDERING INSTRUCTIONS

1. Model Number
2. Cable Length, if Nonstandard
3. Accessories
4. User Tag Data

OTHER M&I PRODUCTS

IPS provides a broad range of measurement and instrument products, including solutions for pressure, flow, analytical, positioners, temperature, controlling and recording. For a listing of these offerings, visit the IPS web site at:

www.ips.invensys.com



IPS Corporate Headquarters
5601 Granite Parkway Suite 1000
Plano, TX 75024
www.ips.invensys.com

Foxboro Global Client Support
Inside U.S.: 1-866-746-6477
Outside U.S.: 1-508-549-2424 or contact
your local Foxboro representative.
Facsimile: 1-508-549-4999

Invensys and Foxboro are trademarks of
Invensys plc, its subsidiaries, and affiliates.
All other brand names may be trademarks of their
respective owners.

Copyright 1992-2009 Invensys Systems, Inc.
All rights reserved

MB 010, 012 Printed in U.S.A.

0209