

Model E69F
Current-to-Pneumatic Signal Converter
Field-Mounted

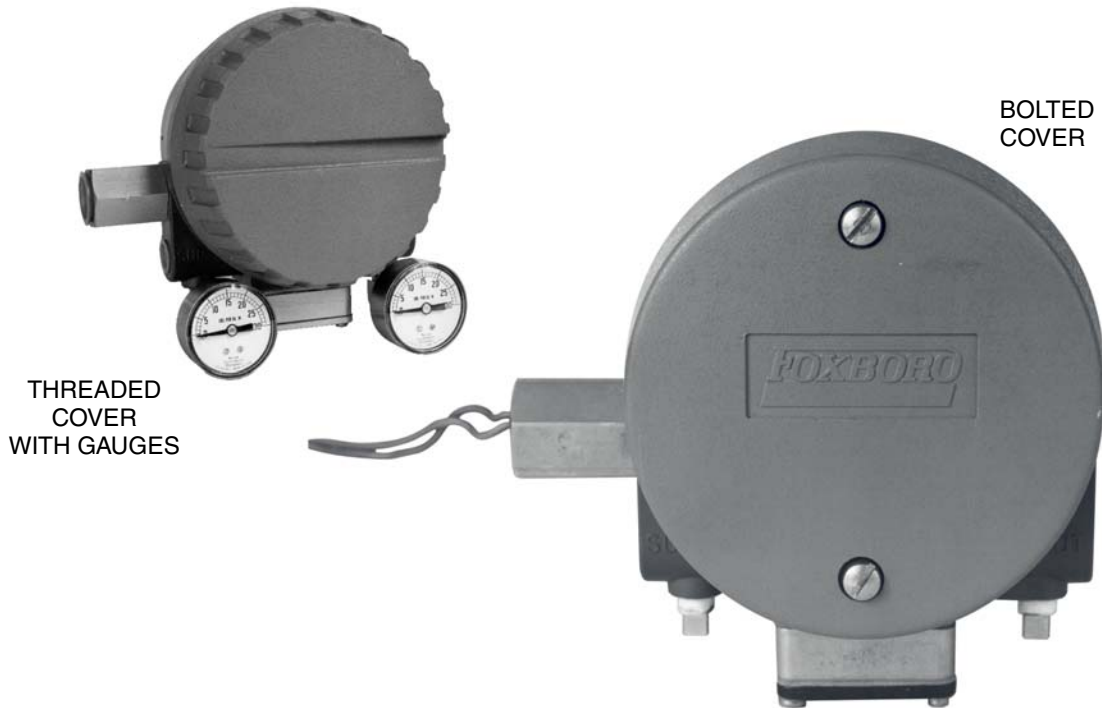

The E69F Field-Mounted Current-to-Pneumatic Signal Converter accepts a standard direct current input signal and converts it to a proportional pneumatic output signal for use with other pneumatic instruments or control valves. As symbolized by the “CE” Logo marking on the product, this product conforms to the applicable European Union Directives.

COMPACT AND EASILY MOUNTED

The E69F Converter is a small, compactly designed device which is very simply connected to both electrical and pneumatic interfaces. It can be easily mounted to a surface, a valve yoke, or to a nominal DN 50 or 2 in vertical pipe.

MINIMAL EFFECTS FROM AMBIENT ATMOSPHERIC CONDITIONS

The design of the galvanometric motor in the E69F Converter provides for generous clearances between coil and housing. Normal atmospheric changes which may cause corrosion and dust

particles do not hinder operation of the mechanism, as sometimes happens with voice coil type instruments.

APPLICATION VERSATILITY

Choice of input and output signals, split input ranges, as well as direct or reverse action, makes this converter easily adaptable for a wide range of applications. Output signals are available to make this converter particularly suitable for use in valve applications.

SHOCK, VIBRATION, AND INCLINATION EFFECTS MINIMIZED

Utilizing stiff feedback flexures and low mass components, the effect of vibration and shock

normally encountered in process applications is minimized. Statically balancing the coil in the unique galvanometric motor greatly minimizes inclination effects.

PERFORMANCE SPECIFICATIONS

(All values are for normal input ranges)

Accuracy

Output Signal Codes 2 and 3

±1.0% of span

Output Signal Codes 7 and 8

±2% of span

Linearity

±0.5% of span, typical
(maximum deviation limited by accuracy specification)

Repeatability

±0.25% of span, typical
(maximum deviation limited by accuracy specification)

Hysteresis

±0.5% of span, typical
(maximum deviation limited by accuracy specification)

Dead Band

0.1% of span

Supply Pressure Effect

A change in supply pressure causes a zero shift of less than 0.04% of span per kPa (0.25% per psi).

Ambient Temperature Effect

A 28°C (50°F) change in ambient temperature, within the operating limits of 0 and 60°C (32 and 140°F), causes zero and span shifts of ±1.0% of span, or less.

Inclination Effect

Maximum zero shift is 0.25% of span for a 5 degree angular change in inclination from the vertical. This error can be eliminated by calibrating instrument at its intended mounting position.

Shock Effect

Maximum zero shift is 0.5% of span when subjected to a shock test level of 300 m/s² (30 "g") measured at the feedback support bracket.

FUNCTIONAL SPECIFICATIONS

Input Signal Ranges

Normal Range	Split Ranges	Input Impedance
4 to 20 mA	4 to 12 or 12 to 20 mA	170 Ω
10 to 50 mA	10 to 30 or 30 to 50 mA	27 Ω

Output Signal

See "Model Code" on page 6.

Instrument Adjustments

Zero

Provided by externally located screwdriver adjustment

Range

Provided by internally located wrench adjustment

Normal Operating Temperature Limits

0 and 60°C (32 and 140°F)

Ambient Temperature Limits

-40 and +80°C (-40 and +180°F)

Relative Humidity Limits

0 to 100% RH, no condensate

Converter Action (as specified)

Direct

Increased input increases the output

Reverse

Increased input decreases the output

Air Consumption

Output Signal Code 2

0.50 m³/h (0.30 scfm)

Output Signal Codes 3, 7, AND 8

1.3 m³/h (0.75 scfm) with 140 kPa, 20 psi, 1.4 bar, or kg/cm² supply

1.7 m³/h (1.0 scfm) with 240 kPa, 35 psi, 2.4 bar, or kg/cm² supply

Pneumatic Capacity

Output Signal Code	Supply		Exhaust	
	m ³ /h	scfm	m ³ /h	scfm
2	1.0	0.60	0.8	0.50
3 and 8	1.9	1.10	1.5	0.90
7	1.2	0.70	1.5	0.90

Supply Pressure (a)

Nominal			Operative Limits		
kPa	psi	bar or kg/cm ²	kPa	psi	bar or kg/cm ²
140	20	1.4	130 & 160	19 & 23	1.3 & 1.6
240	35	2.4	225 & 260	33 & 38	2.3 & 2.6

- a. Supply pressure must not be less than 20 kPa, 3 psi, 0.2 bar or 0.2 kg/cm² above the maximum output signal pressure. Also, supply air to be free of oil, dust, and water per IEC 654-2.

ELECTRICAL SAFETY SPECIFICATIONS

Input Signal (mA)	Testing Laboratory	Types of Protection, Area Classification, and Application Conditions	Available with Model	Electrical Classification Code
4 to 20 or 10 to 50	FM	FM approved explosionproof for Class I, Groups C and D, Division 1; and dust-ignitionproof for Class II, Groups E and G, Division 1. Temperature Class T6.	E69F -T only	CS-E/FD-A (a)
		FM approved nonincendive for Class I, Groups A, B, C, and D, Division 2; and Class II, Group G, Division 2. Also suitable for use in ordinary locations. Temperature Class T6.	E69F -B and -T	CS-E/FN-A
	CSA	CSA certified for use in Class I, Groups A, B, C, and D, Division 2 hazardous locations. Temperature Class T6.	E69F -B and -T	CS-E/CN-A
		CSA certified explosionproof for use in Class I, Group D; Class II, Groups E, F, and G; and Class III, Division 1 hazardous locations. Temperature Class T6.	E69F -T only	CS-E/CD-A (a)
	ATEX	ATEX certified flameproof EEx d for Gas Group IIB, Zone 1. Ta from -40 to +80°C. Temperature Class T5.	E69F -T only	CS-E/LD-E (b)
4 to 20	FM	FM approved intrinsically safe for Class I, Groups A, B, C, and D, Division 1; and Class II, Groups E and G, Division 1; when connected to certified modules per TI 005-101. Temperature Class T6.	E69F -B and -T	CS-E/FB-A
		FM approved intrinsically safe for Class I, Groups A, B, C, and D, Division 1; and Class II, Groups E and G, Division 1; when connected to Honeywell Class 38 Barrier 38454-0000-0110-113-F5B5. Temperature Class T6.	E69F -B and -T	CS-E/FB-H
		OR FM approved intrinsically safe for Class I, Groups C and D, Division 1; and Class II, Groups E and G, Division 1; when connected to Honeywell Class 38 Barrier 38454-0000-0110-(111 or 112) F5B5. Temperature Class T6.		
	CSA	Either 170 or 27 ohm coil CSA certified intrinsically safe for Class I, Groups B, C, and D, Division 1, when connected to CSA certified Invensys Systems I/O modules. Temperature Class T6.	E69F -B and -T	CS-E/CB-A
	ATEX	ATEX certified intrinsically safe EEx ia for Gas Group IIC, Zone 1 and Zone 0. Ta from -40 to +80°C. Temperature Class T4 - T6.	E69F -B and -T	CS-E/KA-E
		ATEX certified nonincendive EEx nA for Group IIC, Zone 2. Ta from -40 to +80°C. Temperature Class T4-T6.	E69F -B and -T	CS-E/KN-A

- a. Use of the optional PG11 Cable Gland is not allowed. Use a flameproof cable gland instead.
- b. Requires E69F Optional Selection -J; Integral Explosionproof Junction Box.

PHYSICAL SPECIFICATIONS

Enclosure

Diecast low copper aluminum alloy body and cover, with an epoxy powder finish. Meets the requirements of IEC IP65 and provides the environmental protection of NEMA Type 4.

Mounting

Valve yoke, surface, or nominal DN 50 or 2 in pipe. Calibrated for vertical mounting unless otherwise specified.

Approximate Mass

2.3 kg (5 lb)

Dimensions

Refer to “Dimensions – Nominal” on page 7, and to Dimension Print DP 018-430.

Input/Output Connections

Electrical

Tapped for 1/2 inch conduit fitting to connect to a pair of 0.5 m (18 in) long 1.00 mm² (18 AWG) twisted leads,

Pneumatic

1/4 NPT for air supply and output signal

Data Plate

Aluminum data label fastened to housing with pressure sensitive adhesive. Includes space for customer tag data up to a maximum of 86 characters and spaces. For additional space, see optional Customer Tag.

OPTIONAL FEATURES

Customer Tag

Stainless steel tag wired to converter for customer tag data that doesn't fit on data plate. There can be a maximum of 10 lines of data with 40 characters and spaces per line. Specify AS Code MTS.

Split Range Input Signal

4 to 12, 12 to 20, 10 to 30, or 30 to 50 mA dc. Selectable using Model Code and specifying split range required.

Alternative Output Signal

Refer to Invensys Foxboro for other than standard output signals.

Explosionproof Junction Box

Integrally mounted to converter. Specify Model Code Suffix -J.

PG11 Trumpet Type Cable Connection

For use with, and assembled to explosionproof (-J) junction box specified above. Also available without (-J) junction box for non-explosionproof applications. Not offered with Electrical Certification Specifications CS-E/CD-A and CS-E/FD-A.

Specify AS Code PG-11.

Adjustable Filter Regulator

Provided without gauge. Specify Model Code Suffix -R.

Supply (Input) and Output Pressure Gauges

Must be selected per output range requirements. Integrally mounted to converter. Specify Model Code Suffix -S.

Miniature Junction Box

Enclosure size is approximately 64 x 58 x 33 mm (2.5 x 2.3 x 1.3 in). Designed to meet the requirements of IEC IP65 and provide the environmental protection of NEMA Type 4. Provided with 1/2 inch NPT conduit connection, 20 mm (M20) threaded hole, or PG11 or PG13.5 trumpet type cable connections. These connections are located for either front or rear cable entry. This junction box is not available for explosionproof applications. Junction box with 1/2 inch conduit connection for front entry is optional selection -M, and with 1/2 NPT conduit connection for rear entry is optional selection -P.

For other types of connections, specify AS Code as described in the table below:

AS Code	Description
MB-A	PG11 connection, front entry
MB-B	PG13.5 connection, front entry
MB-C	M20 connection, front entry
MB-D	PG11 connection, rear entry
MB-E	PG13.5 connection, rear entry
MB-F	M20 connection, rear entry

MODEL CODE

Description	Model
Field-Mounted Current-to-Pneumatic Converter	E69F
Enclosure Bolted cover - weatherproof (for use in all non-explosionproof applications) Threaded cover - explosionproof (must be used in all explosionproof applications) (a)	-B -T
Input Signal Range and Impedance (b) 4 to 20, 4 to 12, or 12 to 20 mA dc; 170 Ω; direct or reverse action 10 to 50, 10 to 30, or 30 to 50 mA dc; 27 Ω; direct or reverse action	I H
Output Signal (b) 20 to 100 kPa, 3 to 15 psi, or 0.2 to 1.0 bar or kg/cm ² 40 to 200 kPa, 6 to 30 psi, or 0.4 to 2.0 bar or kg/cm ² ; or 3 to 27 psi 7 to 125 kPa, 1 to 18 psi, or 0.07 to 1.3 bar or kg/cm ² (c) 7 to 220 kPa, 1 to 32 psi, or 0.07 to 2.2 bar or kg/cm ² (c)	2 3 7 8
Optional Selections (Also refer to "Optional Features" on page 5) Integral explosionproof junction box (a) Miniature junction box with 1/2 inch NPT conduit connection; front entry (d) Miniature junction box with 1/2 inch NPT conduit connection; rear entry (d) Adjustable filter regulator without gauge Supply/output gauges (select per output range requirements)	-J -M -P -R -S
Example: E69F-TI2-J (4 to 20 mA dc input, direct action, 3 to 15 psi output)	

- a. Refer to "Electrical Safety Specifications" on page 4.
- b. Specify input signal range, and whether direct or reverse action, also specify output signal.
- c. Specify Output Signal Code 7 or 8 when used to operate actuators.
- d. Not available with -T Housing.

DIMENSIONS – NOMINAL

$\frac{\text{mm}}{\text{in}}$

E69F — EXPLOSIONPROOF CONSTRUCTION

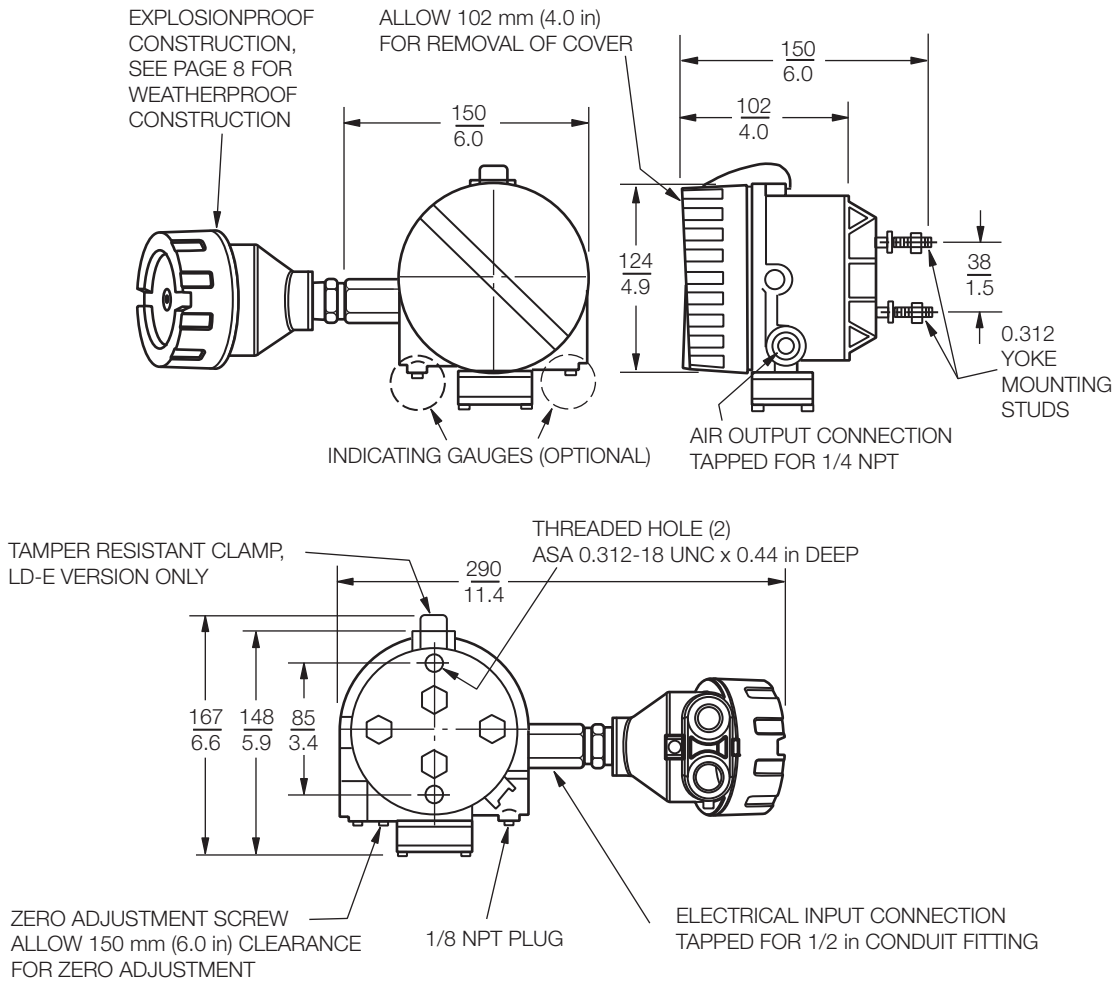

NOTE: 1. REFER TO PAGE 7 FOR E69F WITH OPTIONAL FILTER REGULATOR.
2. REFER TO PAGE 8 FOR E69F WITH OPTIONAL MINIATURE JUNCTION BOX.

$\frac{\text{mm}}{\text{in}}$

E69F — EXPLOSIONPROOF CONSTRUCTION; WITH OPTIONAL FILTER REGULATOR

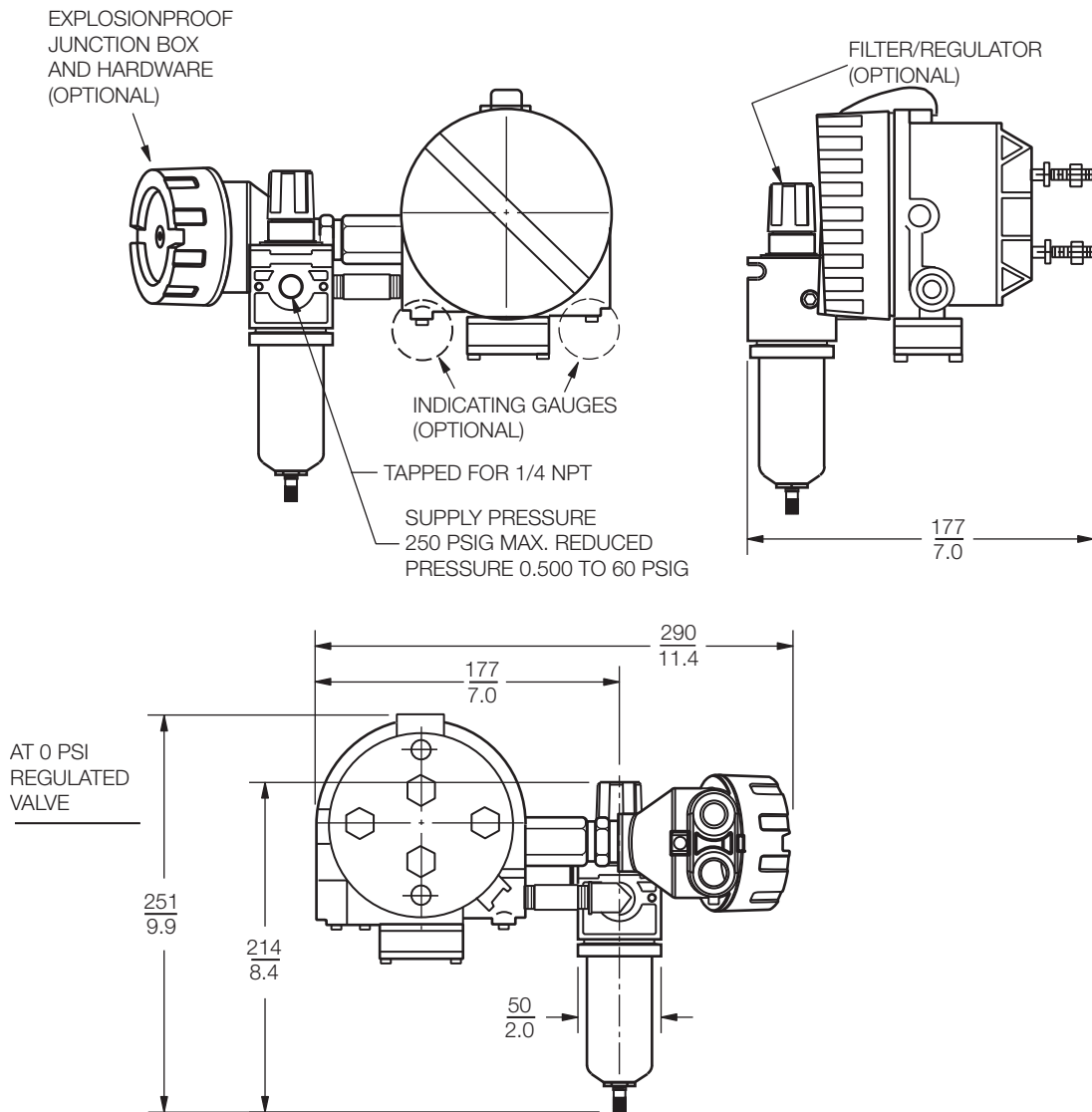

mm
in

E69F — WEATHERPROOF CONSTRUCTION; WITH OPTIONAL MINIATURE JUNCTION BOX

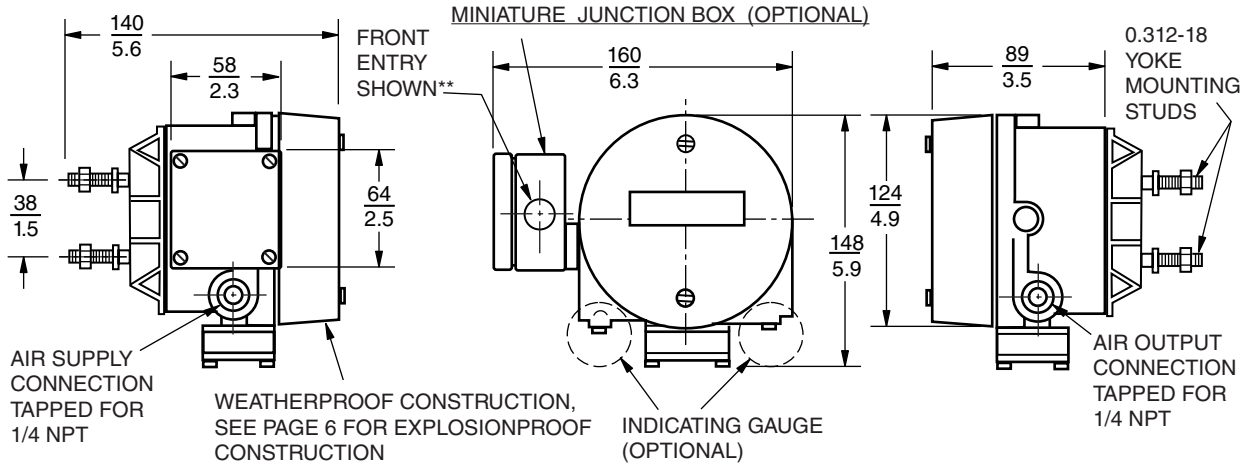

****CONNECTION OPTIONS**

- 1/2 NPT CONDUIT, FRONT ENTRY
- 1/2 NPT CONDUIT, REAR ENTRY

**MODEL CODE
OPTIONAL SELECTION**

- M
- P

**AS REFERENCE
OPTIONAL SELECTION**

- | | |
|--------------------------------|------|
| PG11 CABLE, FRONT ENTRY | MB-A |
| PG11 CABLE, REAR ENTRY | MB-D |
| PG13.5 CABLE, FRONT ENTRY | MB-B |
| PG13.5 CABLE, REAR ENTRY | MB-E |
| M20 THREADED HOLE, FRONT ENTRY | MB-C |
| M20 THREADED HOLE, REAR ENTRY | MB-F |

NOTES

ORDERING INSTRUCTIONS

1. Model Number
2. Specific Input Signal (for Code I or H)
3. Direct or Reverse Converter Action
4. Electrical Classification (Specify Electrical Classification Code)
5. Optional Selections other than those specified in Model Number (AS Codes)
6. Customer Tag Data and Application

OTHER FOXBORO PRODUCTS

The Foxboro product lines offer a broad range of measurement and instrument products, including solutions for pressure, flow, analytical, temperature, positioning, controlling, and recording. For a list of these offerings, visit our web site at:

www.fielddevices.foxboro.com