

PSS 1-8A6 A

LOW POWER Models 84F (Flanged Body, Style A), 84W (Wafer Body), and 84S (Sanitary) I/A Series® Intelligent Vortex Flowmeters with HART® Communication Protocol

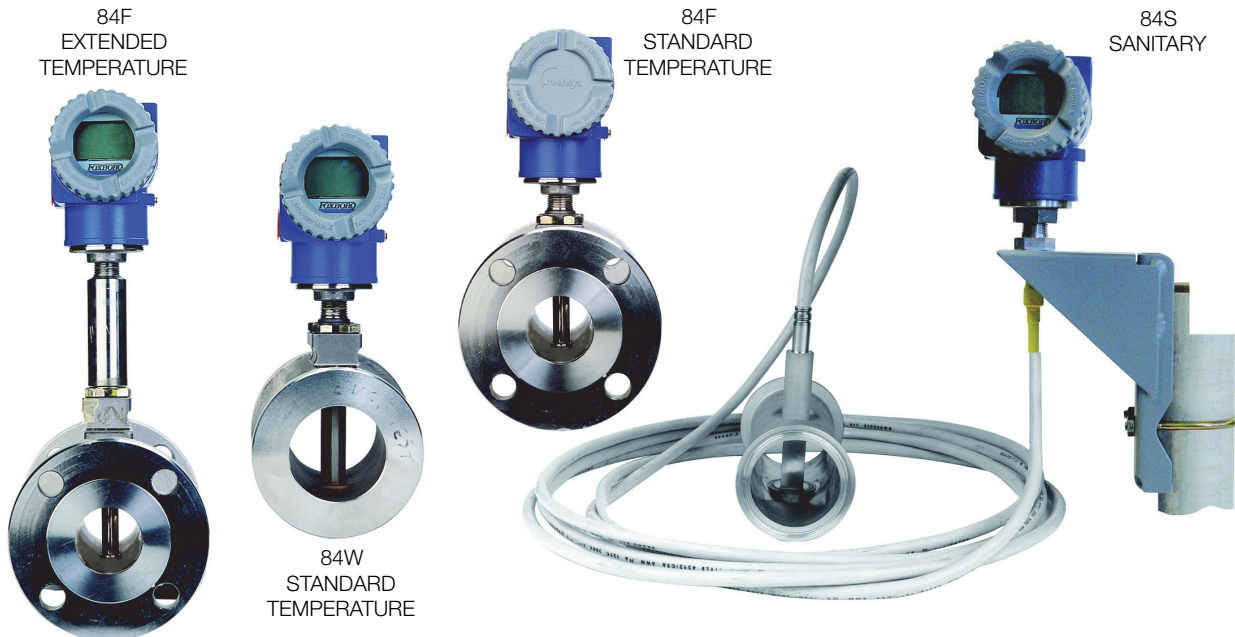

The Foxboro® brand I/A Series® LOW POWER Models 84F, 84W, and 84S are part of a family of intelligent, high performance, flanged, wafer body, and sanitary vortex flowmeters. They transmit a digital and pulse output signal, as applicable, using HART® communication protocol for remote configuration, calibration, and monitoring. An on-board LCD indicator/configurator is offered for local configuration.

FEATURES

- ▶ Liquid, gas, or steam applications.
- ▶ For use with battery or solar power installations.
- ▶ Flanged or wafer body designs:
 - 3/4 to 12 in (DN 15 to DN 300) flanged body.
 - 3/4 to 8 in (DN 15 to DN 200) wafer body.
- ▶ Sanitary flowtube design:
 - Complies with 3-A sanitary standards
 - 2 and 3 in (DN 50 and DN 80) Sizes
 - 316L stainless steel flowtube with 25RA finish
 - Complete line of sanitary end connections
- ▶ HART communication protocol.
- ▶ Best in class accuracy:
 - $\pm 0.5\%$ of reading in liquids.
 - $\pm 1.0\%$ of reading in gas and steam.
- ▶ Widest rangeability in class.
- ▶ ActiveTuning™ algorithm:
 - Real time Reynolds number (R_D) low flow correction down to R_D of 5000.
 - Compensation for piping effects.
 - Adaptive filtering and signal conditioning.
 - Tunable for specific operating conditions.
- ▶ DirectSense™ technology with lifetime sensor warranty.
- ▶ Pulse Output provides raw or scaled frequency, or total.
- ▶ CE marked; complies with EMC European Union and PED Directives, and NAMUR NE 21 interference immunity requirement.
- ▶ A free-to-use, flow sizing program is available on the internet at www.FlowExpertPro.com.

WIDE VARIETY OF APPLICATIONS

These Low Power Vortex Flowmeters differ from other 84 Series Vortex flowmeters in that the supply current is fixed at a constant 10 mA, and remain in operation down to a minimum voltage of 10 V dc. They are intended for use with battery power with any form of recharging technology such as solar arrays or alternators.

The Models 84F and 84W set the example for industry standards whether the application requires accuracy for totalizing and batching; utility metering of fluids in the process industries; fuel, air, steam, or gas metering for the measurement of energy in any high use application; or stability and repeatability for process control.

The Model 84S is offered with a large selection of the most popular, common sanitary end connections. For users who do not require 3-A compliance, a Class 150 RF flange end connection is also offered. It is ideally suited for the pharmaceutical, food, and dairy industries. Difficult fluids, such as some slurries, can also be measured. It can also be configured, for example, to measure the flow of liquids in a batch process without measuring the inert gas following the batch, thus providing an accurate measurement of the liquid only.

COMPLIANCE WITH EUROPEAN UNION DIRECTIVES

- ▶ Complies with Electromagnetic Compatibility Requirements of EMC Directive 2004/108/EC by conforming to the following EN and IEC Standards: EN 61326-1 and IEC 61000-4-2 through 61000-4-6.
- ▶ Complies with NAMUR NE 21 Interference Immunity Requirement (EMC).
- ▶ Complies with Pressure Equipment Directive (PED) 97/23/EC.
- ▶ Complies with all applicable European Union Directives (CE Logo marked on product).

PATENTED *DIRECTSENSE* TECHNOLOGY ENSURES BEST PERFORMANCE AND RELIABILITY

This patented family of vortex flowmeters has the high accuracy and rangeability of positive displacement and turbine flowmeters without the mechanical complexity and high cost. They provide flow rate accuracy of $\pm 0.5\%$ in liquids and $\pm 1.0\%$ in gas and steam. It utilizes patented *DirectSense* technology to eliminate routine problems encountered with other vortex meters. *DirectSense* technology measures pressure pulses from vortex shedding directly, without losses due to mechanical linkages. *DirectSense* technology benefits include:

- ▶ Provides best performance in class.
- ▶ Increased measurement sensitivity for wider rangeability.
- ▶ Greater immunity to pipe vibration.
- ▶ High reliability backed by lifetime sensor warranty.
- ▶ Replaceable sensor without recalibrating (Models 84F and 84W only).

SIMPLIFIED START-UP

The flowmeter is easily installed and configured. Simply wire it to a proper power source, an I/O module, or controller, and it is ready to measure flow.

Invensys will preconfigure the flowmeter using data supplied by the customer. Preconfigured flowmeters can be used as shipped, but for more precise application, they should be configured to specific process usage. The configurator allows selection of fluid type, and provides general default configurations when process conditions are not available.

ACTIVETUNING ALGORITHM

Reynolds Number

Patented algorithm improves accuracy performance down to a Reynolds Number of 5000.

Compensations for Piping Effects

When it is not possible to provide the recommended pipe diameters of unobstructed straight pipe upstream of the flowmeter, it can be configured to compensate for most of the common non-ideal upstream conditions, e.g. elbows and reducers. Straight runs as short as 5-pipe diameters can be configured to achieve full accuracy.

Adaptive Filtering and Signal Conditioning

A patented, adaptive filtering algorithm provides real-time, dynamic frequency filters that follow the vortex shedding frequency. This results in unsurpassed low-flow measurement capability and vibration immunity. This is incorporated with a digital smoothing algorithm that conditions the raw vortex signal to virtually eliminate dropped or added pulses, further enhancing low-flow performance.

Tunable for Specific Operating Conditions

Configurable parameters for Low Flow Cut-in and damping allow tuning for specific flow conditions.

COMPACT AND EFFICIENT DESIGN

Since these flowmeters have no moving parts, they are very durable and reliable. This simple design ensures low initial operating and maintenance costs, and therefore an overall lower cost of ownership.

Models 84F and 84W

The 84F and 84W mount between ANSI or EN 1092-1 raised face flanges (Model Code). Custom flange surfaces can also be used.

The electronics housing is of explosionproof and flameproof construction and provides environmental protection to the enclosed electronics. It is offered integrally mounted or remote mounted.

The flowmeter's simple, modular design requires minimum maintenance. Common, field replaceable

parts are used, including the sensor assembly and amplifier. The amplifier can be replaced without interrupting the flow in the pipe, and sensor can be replaced without process shutdown when an isolation valve is installed. Since a single device is used for multiprocess-fluid applications, ordering is simplified and spare part needs minimized.

Model 84S - 3-A/CIP/SIP DESIGN

This sanitary flowmeter is designed for either general sanitary applications or in CIP (Clean-In-Place) 3-A compliant sanitary service. The meter is a crevice-free design with no moving parts, and allows for in-line cleaning (CIP) using various combinations of cleaning solutions, air purging, or saturated steam (SIP) at temperatures to 350 °F (177 °C).

It is offered in 2- and 3-in (DN 50 and DN 80) line sizes with a selection of popular end connections. The process-wetted parts are 316 ss and 316L ss, and finished to 25 microinch per 3-A standards.

The electronics housing is the same design as the 84F and 84W, and also provides environmental protection to the enclosed parts. The plug-in amplifier can be calibrated in place, and can be replaced without interrupting the flow in the pipe.

USABLE IN HAZARDOUS AREA LOCATIONS

These flowmeters meet numerous agency requirements for hazardous locations.

MEASUREMENT INTEGRATION

These flowmeters provide efficient integration of measurements into HART process control schemes. They operate by using a bidirectional digital signal superimposed on the fixed⁽¹⁾ 10 mA supply current. They are also offered with or without a pulse output. Remote communication of digital values plus status and configuration information can be achieved via HART communication protocol.

Configurators used with the HART versions are:

- ▶ The HART Communicator (users having a HART Communicator for other devices can have them upgraded with Invensys software to accommodate these flowmeters).
- ▶ The local digital indicator/configurator with pushbuttons.
- ▶ A PC-based configurator.

With HART, digital multidropping is permitted. This is the connection of several transmitters to a single communications line. Up to fifteen transmitters can be connected on a single twisted pair of wires or over leased telephone lines.

REMOTE MOUNTED ELECTRONICS HOUSING

A remote mounted housing allows access to the amplifier and other housing electronics when the measurement is not in an easily accessible location. The remote housing is supported by a bracket, which is mounted to a surface or nominal 2-in or DN 50 pipe.

The 84F and 84W flowmeters are offered with either an integrally mounted or remote mounted housing. With remote mounting, the housing can be located up to an interconnecting cable length of 50 ft (15.2 in) from the flowtube without loss of low level signal.

The 84S sanitary flowmeter is only available with a remote mounted housing. Interconnection is via a 15 ft (4.5 m) cable which is integral to the flowtube.

LOCAL DIGITAL INDICATOR/CONFIGURATOR

This is a full feature, 16-character digital indicator and configurator. Total flow and/or the instantaneous flow rate may be displayed in user-selected flow units. The display may be configured for either flow or total, or to toggle between them. Four pushbuttons on the indicator are used to configure the flowmeter.

ISOLATION VALVE (84F AND 84W ONLY)

An isolation valve allows the sensor to be removed or replaced without interrupting the flow in the pipe.

FLOWEXPERTPRO™ PROGRAM

The FlowExpertPro program is primarily used to size Foxboro brand flowmeters. It also ensures that the user has selected the proper flowmeter type for his application. Invensys provides this meter selection tool as a free web site to all users, without the need for registration. In addition to flowmeter selection and sizing, the FlowExpertPro program includes the following features:

- ▶ Incorporates a large library of the physical properties of typical process fluids.
- ▶ Displays results in tabular or graphic format.
- ▶ Allows user to save, print, or E-mail results.
- ▶ Provides reference to applicable flowmeter PSSs and other related flowmeter documentation.

The program calculates minimum and maximum flow rates, rangeability, pressure loss, and Reynolds Number, using established flow equations. It also allows for material and flange selection, and provides ANSI or metric flange recommendations for predicted flow pressure and temperature. You are invited to visit www.FlowExpertPro.com to access this program, or contact Invensys for further information and technical support.

(1) A 4 to 20 mA current signal is not available with this LOW POWER Vortex Flowmeter.

OPERATING CONDITIONS

**DUAL MEASUREMENT FLOWMETER
(84F ONLY)**

Dual measurement flowmeters provide the user with redundant sensors and electronics. Two electronics housings and sensors are mounted to a common flowmeter body assembly. Should one transmitter fail, the redundant measurement avoids the necessity of shutting down the process. The failed transmitter can then be replaced at some later noncritical time. Applications include Safety Shutdown Systems (independent of Process Measurement Network), Safety Backup for critical flow loops, Comparative Verification of Measurement for high accuracy precision loops, or just for dual communications paths with the same primary element. See Figure 1.

Figure 1. Dual Measurement Flowmeter (84F Only)

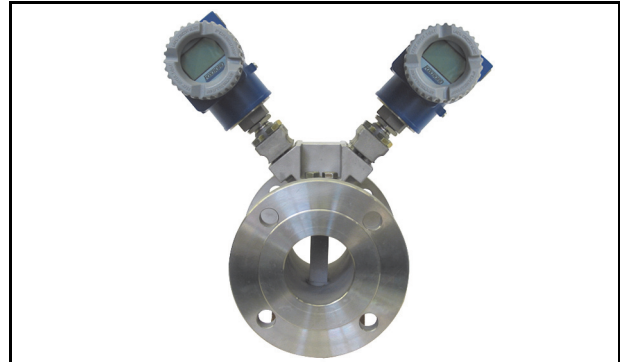

OPERATING CONDITIONS

Influence	Factory Calibration Conditions (a)	Operating Limits (b)
Process Fluid	Clear Water	Liquid, Gas, and Steam
Process Temperature (84F and 84W) <ul style="list-style-type: none"> ▶ Std. Temp. Version/Fluorolube Fill ▶ Std. Temp. Version/Silicone Fill ▶ High Temp. Version/Unfilled 	<ul style="list-style-type: none"> ▶ 70 to 85°F (20 to 30°C) ▶ 70 to 85°F (20 to 30°C) ▶ 70 to 85°F (20 to 30°C) 	<ul style="list-style-type: none"> ▶ 0 and +200°F (-20 and +90°C) ▶ 0 and +400°F (-20 and +200°C) ▶ 400 and 800°F (200 and 430°C)
Process Temperature (84S)	70 to 85°F (20 to 30°C)	0 and 350°F (-18 and +177°C)
Ambient Temperature (Housing) <ul style="list-style-type: none"> ▶ with Indicator/Configurator ▶ without Indicator/Configurator 	<ul style="list-style-type: none"> ▶ 70 to 85°F (20 to 30°C) ▶ 70 to 85°F (20 to 30°C) 	<ul style="list-style-type: none"> ▶ 0 and +176°F (-20 and +80°C) (c) ▶ -40 and +176°F (-40 and +80°C) (c)
Relative Humidity	50 to 90%	0 and 100%
Supply Voltage	24 ± 0.5 V dc	10 and 42 V dc (d)

- (a) Assumes ANSI Schedule 40 process piping; flanges bored to interfacing pipe I.D.; piping and flowmeter body bores aligned to within 2% of meter bore; gaskets to be 3.18 mm (0.125 in) thick and not protruding into pipeline; a minimum of thirty pipe diameters of straight pipe upstream and five pipe diameters downstream of flowmeter; clear water is free from air or particles.
- (b) Limits are based on nonflashing, noncavitating conditions. A minimum positive back pressure is required for proper operation to avoid these effects.
- (c) The 176°F (80°C) temperature is extended to 185°F (85°C) with certain electrical approvals or certifications. Refer to Electrical Safety Specifications table.
- (d) Supply current is fixed at a constant 10 mA and remains in operation down to a minimum terminal voltage of 10 V dc. See Power Supply Requirements note in Functional Specifications section.

PERFORMANCE SPECIFICATIONS

Under calibrated operating conditions unless otherwise stated

Factory Calibrated Flow Ranges - Models 84F and 84W

Nominal Meter Size	Nominal Mean K-Factor in Pulses/ft ³ (Pulses/L) (a)	Factory-Calibrated Flow Range for Water (b)		
		Range in USgpm	Range in L/s	Range Reynolds Number (R _D)
DN 15 (3/4 in)	5,580 (197)	6.9 to 34	0.43 to 2.1	30,000 to 150,000
DN 25 (1 in)	2,250 (79.5)	8.9 to 56	0.56 to 3.5	30,000 to 190,000
DN 40 (1 1/2 in)	570 (20.1)	14 to 140	0.88 to 8.7	30,000 to 300,000
DN 50 (2 in)	258 (9.11)	18 to 230	1.1 to 15	30,000 to 380,000
DN 80 (3 in)	78.7 (2.78)	34 to 500	2.1 to 32	38,000 to 570,000
DN 100 (4 in)	34.8 (1.23)	59 to 890	3.7 to 56	50,000 to 750,000
DN 150 (6 in)	10.00 (0.353)	140 to 2,000	8.5 to 130	76,000 to 1,100,000
DN 200 (8 in)	4.26 (0.150)	240 to 3,600	15 to 220	100,000 to 1,500,000
DN 250 (10 in) (c)	1.99 (0.0703)	390 to 5,800	24 to 370	130,000 to 1,900,000
DN 300 (12 in) (c)	1.16 (0.0410)	560 to 8,400	36 to 530	160,000 to 2,300,000

(a) The K-factor is the relationship between input (volumetric flow rate) and the output (pulse rate). Reference K-factor is the arithmetic mean value of K-factor over a designated flow rate range (reference conditions). The mean K-factor is derived as:

$$\text{Mean K-factor} = (\text{KMAX} + \text{KMIN}) / 2$$

where KMAX is the maximum K-factor and KMIN is the minimum K-factor over the calibrated flow range.

(b) Factory calibrated Reynolds Number range applies to standard temperature sensor without isolation valve. Other sensor selections and manifold selections may alter the calibration range. Visit FlowExpertPro.com sizing program for specific calibration ranges.

(c) The 10 and 12 in (DN 250 and DN 300) flowmeters are available with the Model 84F only.

Factory Calibrated Flow Ranges - Model 84S

Nominal Meter Size	Nominal Mean K-Factor Pulses/USgal (Pulses/L) (a)	Factory-Calibrated Flow Range for Water (b)		
		USgpm Range	L/s Range	RD Range
2 in (DN 50)	37.9 (9.96)	10.8 to 171	0.684 to 10.8	100,000 to 380,000
3 in (DN 80)	10.4 (2.75)	25.5 to 403	1.61 to 25.4	38,000 to 570,000

(a) The K-factor is the relationship between input (volumetric flow rate) and the output (pulse rate). Reference K-factor is the arithmetic mean value of K-factor over a designated flow rate range (reference conditions). The mean K-factor is derived as:

$$\text{Mean K-factor} = (\text{KMAX} + \text{KMIN}) / 2$$

where KMAX is the maximum K-factor and KMIN is the minimum K-factor over the calibrated flow range.

(b) Factory calibrated Reynolds Number range applies to standard temperature sensor. Other sensor selections and manifold selections may alter the calibration range. Visit FlowExpertPro.com sizing program for specific calibration ranges.

PERFORMANCE SPECIFICATIONS

Accuracy for Liquids (84F and 84W)

Accuracy within the calibrated range is as follows (also see Figure 2):

- ▶ Above 30,000 R_D ; $\pm 0.5\%$
- ▶ Between 20,000 and 30,000 R_D ; $\pm 1.0\%$
- ▶ Between 5,000 and 20,000 R_D ; $\pm 2.0\%$

Accuracy for Liquids (84S)

Accuracy within the calibrated range is as follows (also see Figure 3):

DN 50 (2 in) Flowmeter

- ▶ Above 100,000 R_D ; $\pm 0.5\%$
- ▶ Between 20,000 and 100,000 R_D ; $\pm 1.0\%$
- ▶ Between 5,000 and 20,000 R_D ; $\pm 2.0\%$

DN 80 (3 in) Flowmeter

- ▶ Above 38,000 R_D ; $\pm 0.5\%$
- ▶ Between 20,000 and 38,000 R_D ; $\pm 1.0\%$
- ▶ Between 5,000 and 20,000 R_D ; $\pm 2.0\%$

Accuracy for Gases and Steam (84F, 84W, and 84S)

Accuracy within the calibrated range is as follows:

- ▶ Above 20,000 R_D ; $\pm 1.0\%$
- ▶ Between 5,000 and 20,000 R_D ; $\pm 2.0\%$

NOTE

To achieve the liquid, gas, and steam accuracies stated above, the flowing density and viscosity must be entered in the database configuration. Also refer to FlowExpertPro.com to determine the accuracy for specific applications.

Figure 2. Flowmeter Accuracy for Liquids - 84F and 84W

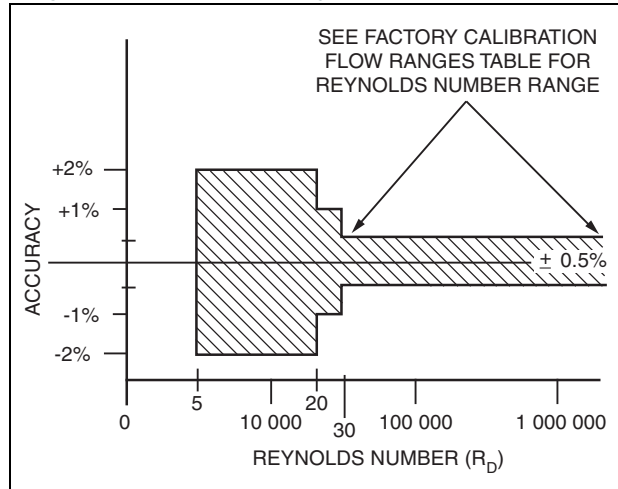
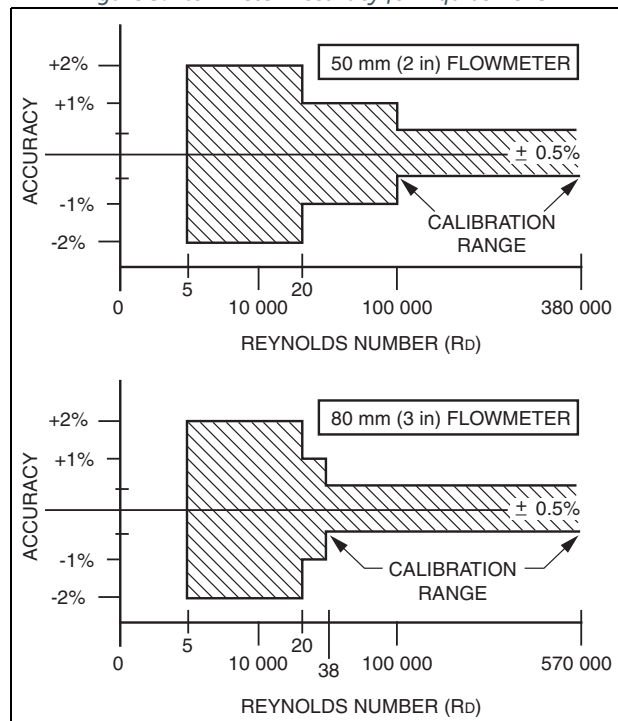

Figure 3. Flowmeter Accuracy for Liquids - 84S



Supply Voltage Effect (Within Stated Limits)

- ▶ With Pulse Output: No effect on accuracy
- ▶ With Digital Output: No effect on accuracy

Process Temperature Effect on K-Factor

There is an effect on the reference K-factor due to a diameter change of the flowtube bore with temperature. The effect is -0.3% of flow rate per 100°F (55°C) increase in temperature. These flowmeters will automatically recompute a flowing K-factor when process temperature is entered in the database fluid definition.

Ambient Temperature Effect (Amplifier only)

- ▶ With Pulse Output
±0.01% of reading from
-40° to +176°F (-40° to +80°C)⁽²⁾
- ▶ With Digital Output
±0.01% of reading from
-40° to +176°F (-40° to +80°C)⁽²⁾

Relative Humidity Effect

No effect if covers and conduit seals are properly installed in accordance with applicable installation instructions.

EMI and RFI Effects

The flowmeters meet the EMI and RFI requirements of EN 61326-1.

Vibration Effect

Vibration can affect the flow measurement output of a Vortex flowmeter in the form of added pulses, but with the built-in Tuning functions and Low Flow Cut-in adjustability, these effects can be minimized. Invensys has tested this meter with vibrations of up to 3 “g” of acceleration with no physical damage, no shift in calibration after the test, and no loss of communications throughout the test.

Position Effect (Filled Pipe Conditions)

For most applications, the flowmeter can be mounted in a pipeline which may run in any direction from the vertical (flow in upward direction) to the horizontal. Measurement of liquid and gas streams is not affected by the pipeline orientation or the flowmeter orientation in the pipeline.

For saturated steam, the recommended flowmeter position is in a horizontal pipe. With an integrally mounted electronics housing, it is recommended that the housing be located below the pipeline.

For superheated steam, the electronics housing may be left or right or below the pipeline. The flowmeter should be insulated to maintain superheat conditions within the flowmeter, as well as insulating the electronics away from the rising heat. The electronics temperature should not exceed 176°F (80°C) under any conditions.

Refer to “RECOMMENDED MOUNTING ARRANGEMENTS” on page 22 for further information.

FUNCTIONAL SPECIFICATIONS**Outputs**

These flowmeters with full-featured electronics can support the following outputs:

- ▶ HART Version -L: Digital output with a pulse output
- ▶ HART Version -M: Digital output without a pulse output

Digital Output

Digital information is superimposed on the power supply loop at 1200 baud. Output is fixed at 10 mA. See “Remote Digital Communication” on page 9.

⁽²⁾ The 176°F (80°C) temperature may be extended to 185°F (85°C). Refer to Electrical Safety Specifications section.

FUNCTIONAL SPECIFICATIONS

Pulse Output

The pulse output can be configured with the full-function electronics: raw pulse, rate pulse, or total pulse.

- ▶ Raw Pulse: This is the vortex shedding frequency directly passed through providing an instantaneous, nondampened frequency output.
- ▶ Rate Pulse: This is a 50% duty cycle pulse output with a frequency range of 0 to 10, 0 to 100, or 0 to 1000 Hz, proportional to zero flow to the full range flow rate/upper range value (URV).
- ▶ Total Pulse: This is also a 50% duty cycle pulse output that is configured to provide a pulse when a determined volumetric/totalized unit has flowed through the meter.

Pulse Output Specifications

The pulse output is an externally powered 2-wire transistor switch type output. This output can be configured using local or any applicable HART configuration device to select any one of the three types of pulse outputs. The following specifications apply to all three types of pulse outputs:

- ▶ Isolated 2-Wire Transistor Switch (type NPN low side switch)
- ▶ Applied Voltage: 5 to 30 V dc
- ▶ Maximum "ON" State Voltage Drop: 1.0 V dc
- ▶ Maximum "ON" State Current: 20 mA
- ▶ Reverse polarity protected
- ▶ Short circuit protected
- ▶ Configurable to pull up or pull down counters.

Output Damping

Damping smooths the flow rate output, and averages instantaneous changes over the selected flowmeter response time to the control system. Damping is an exponential filter with a selectable time constant; it can be set between 0 and 32 seconds. An eight second damping factor will pass 64% of the step change in this time period.

Damping applies to all outputs except the raw pulse output where no damping is applied to the direct vortex shedding frequency.

Response Time (Without Damping)

Digital Mode

0.5 second or the vortex shedding period for frequencies less than 2 Hz.

Pulse Output Mode

- ▶ Raw Pulse: Vortex shedding frequency
- ▶ Rate or Total Pulse: 0.25 s or the vortex shedding period for frequencies less than 2 Hz.

Remote Digital Communication

Remote digital communication is via a HART Communicator or PC-based configurator at a communication rate of 1200 baud, and a rated communication distance of 6000 ft (1800 m). Remote digital communication is also via an I/A Series System.

Local Configuration

In addition to remote communications, a local digital indicator/configurator with pushbuttons is also available for local interrogation and configuration.

Communication Format

Digital communications is provided in the digital mode based upon the FSK (Frequency Shift Keying) technique.

Write Protect Jumper

A write protect jumper provides additional security by allowing the user to prevent the local indicator (configurator) and remote configurator from writing to the electronics. This write protection capability meets the security requirements of ISA-584.01-1986.

On-Line Diagnostics

Flowmeter uses many internal diagnostic functions including hardware checks, and internal code and database validation. Error checking and diagnostic codes are also embedded in the communications protocol. These diagnostics are performed at startup and as continuous background checks.

Offline Diagnostics (Self-Test)

The configurators allow self-tests to be initiated to validate the transmitter electronics. This test uses an internally generated frequency signal.

Password Protection

This is provided in the local display/configurator mode to assure operating security. A second level of protection is provided for configuration security.

Power Supply Requirements

- ▶ Supply Voltage Limits: 10 and 42 V dc
- ▶ Supply Current: 10 mA dc nominal

NOTE

For proper operation, 10 V dc must be maintained at the flowmeter terminals. For HART communications, a 250 Ω load resistor must be included in the power supply loop, and a supply voltage of 12.5 V dc must be maintained. See installation MI for typical installation topologies.

Flowmeter Ranges

Flowmeter is shipped with flow range specified in the sales order or with a default flow range equal to the meter capacity. It can be reranged by the user keeping the same flow rate units, choosing new flowrate units from a built-in menu-selectable list, or entering custom flow rate units. Also refer to the FlowExpertPro sizing program.

Nominal Flow Velocity Limits

These limits can be calculated using Table 1 and Table 2. In the tables, ρ_f is the fluid density at flowing conditions in lb/ft³ for U.S. customary units, or in kg/m³ for SI units. The specifications apply for most applications, but can deviate slightly for some combinations of density and line size.

These tables are included for reference only. Please use the sizing program at www.FlowExpertPro.com to determine flow velocity limits.

Table 1. 84F and 84W Nominal Flow Velocity Limits Standard and Extended Temperature Range

Range Limit	Standard Temperature Range		Extended Temperature Range	
	ft/s	m/s	ft/s	m/s
Lower	$2.5/\sqrt{\rho_f}$	$3.0/\sqrt{\rho_f}$	$5.0/\sqrt{\rho_f}$	$6.0/\sqrt{\rho_f}$
Upper	$250/\sqrt{\rho_f}$	$300/\sqrt{\rho_f}$	$250/\sqrt{\rho_f}$	$300/\sqrt{\rho_f}$

Table 2. 84S Nominal Flow Velocity Limits Standard Temperature Range (a)

Range Limit	ft/s	m/s
Lower	$4.0/\sqrt{\rho_f}$	$4.8/\sqrt{\rho_f}$
Upper	$200/\sqrt{\rho_f}$	$240/\sqrt{\rho_f}$

(a) Extended temperature range not available with 84S.

Reference K-Factor

The reference K-factor is a coefficient that specifies the flowmeter calibration and is expressed as pulses per unit volume, where pulses/unit volume = pulses per second divided by volume flow per second.

The reference K-factor is the arithmetic mean value of K over the factory-calibrated flow range. It is determined at the factory by actual flow calibration with water by comparison to a master flowmeter calibration. Both calibrations are traceable to NIST. The reference K-factor is entered in the flowmeter database and stamped on the data plate. Once established, this K-factor is applicable to gas, liquid, or steam.

Flowing K-Factor

The flowing K-factor is a conversion from the K-reference to specified flowing units, and can be corrected for the configurable bias functions.

- ▶ Process Temperature
- ▶ Mating Pipe
- ▶ Upstream Disturbances

K-Factor Bias

Provisions are made in the configuration menu to bias the flowmeter K-factor by a percent (%) value. Flowing K-factor value will be automatically recalculated when the % bias is entered.

Process Temperature Correction

The flowmeter computes a corrected K-factor at the specific process temperature entered by the user.

Static Pressure Limits

Minimum Static Pressure

The minimum static pressure is that pressure which is sufficient to prevent flashing and meet the pressure drop requirements to attain maximum flow rate. Refer to FlowExpertPro sizing program.

Maximum Static Pressure - 84F and 84W

1500 psi (10 340 kPa) or that imposed by flange rating.

Maximum Static Pressure - 84S

2 in or DN 50 Size: 250 psi (1725 kPa) at 100 °F (38 °C), or that imposed by process piping.

3 in or DN 80 Size: 150 psi (1035 kPa) at 100 °F (38 °C), or that imposed by process piping.

Flange Pressure-Temperature Ratings

See Figures 4 through 6 for ANSI flange pressure-temperature ratings per ASME B16.5.

See Figures 7 through 9 for metric flange pressure-temperature ratings per EN 1092-1.

See Figure 10 for pressure-temperature limits when isolation valves are used.

Also note the temperature limit when fluorolube fill (200°F/90°C) or silicone fill (400°F/200°C) is used, or when no fill (800°F/430°C) is used with extended temperature applications.

The flange ratings in Figures 4 through 10 are also embedded in the FlowExpertPro sizing program.

Approximate Pressure Loss (Pressure Drop)

The maximum pressure loss at maximum flow for any fluid is 8 psi (55 kPa). For many flow conditions, however, the actual pressure loss is much less than 8 psi (55 kPa). Use the FlowExpertPro sizing program to determine actual pressure loss for a given set of flow conditions.

Minimum Back Pressure (Volatile Liquids or Low Pressure Conditions)

Any condition that tends to contribute to the release of vapor from the liquid (flashing, which may also induce cavitation) shall be avoided by proper installation and operation of the flowmeter within the rated flow rate range. Location of flowmeter should consider the need for using a back-pressure valve, or for increasing inlet pressure. To avoid flashing and to ensure stable vortex generation, the minimum back pressure should be:

$$P_G = (3)(\Delta P) + (1.25)(p_v) - (p_{atm})$$

where

- P_G = Gauge pressure in kPa or psi five pipe diameters downstream of the flowmeter
- ΔP = Pressure loss in kPa or psi; see “Approximate Pressure Loss (Pressure Drop)” on page 11
- p_v = Vapor pressure at line conditions in kPa or psi absolute
- p_{atm} = Atmospheric pressure in kPa or psi absolute

Figure 4. ANSI Flange Ratings; per ASME B16.5; Group 2.2 Materials

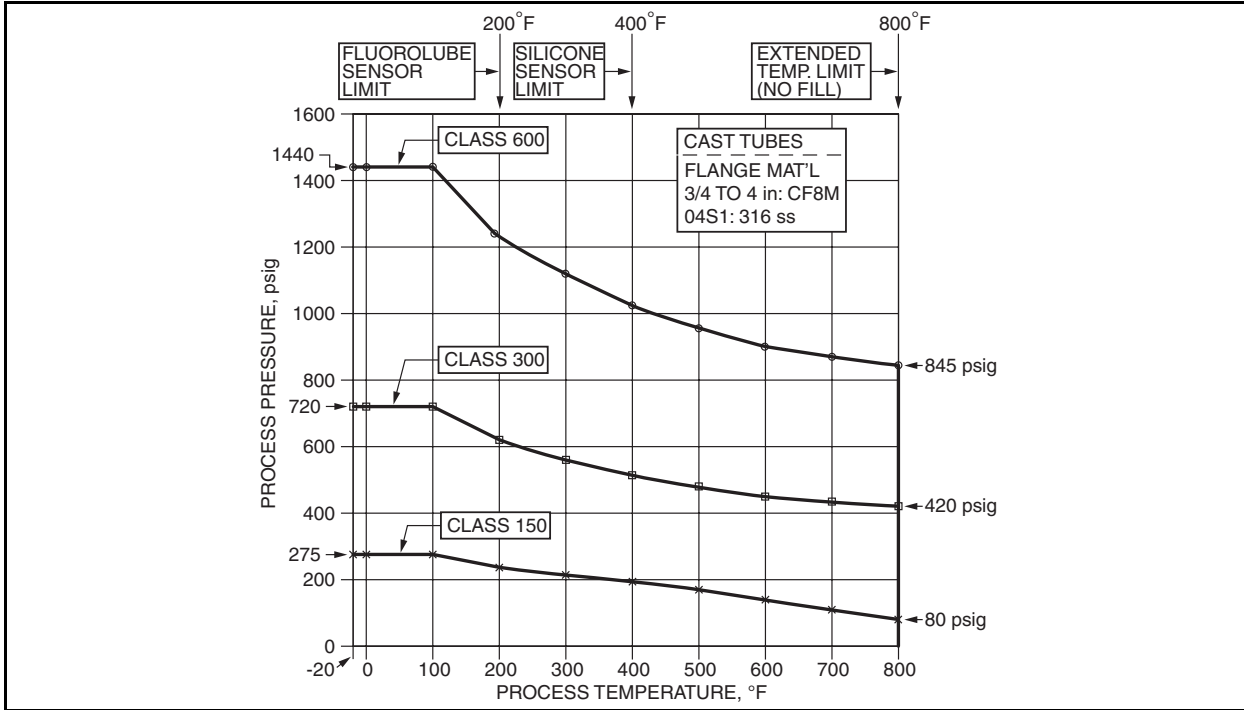

Figure 5. ANSI Flange Ratings; per ASME B16.5; Group 2.1 Materials

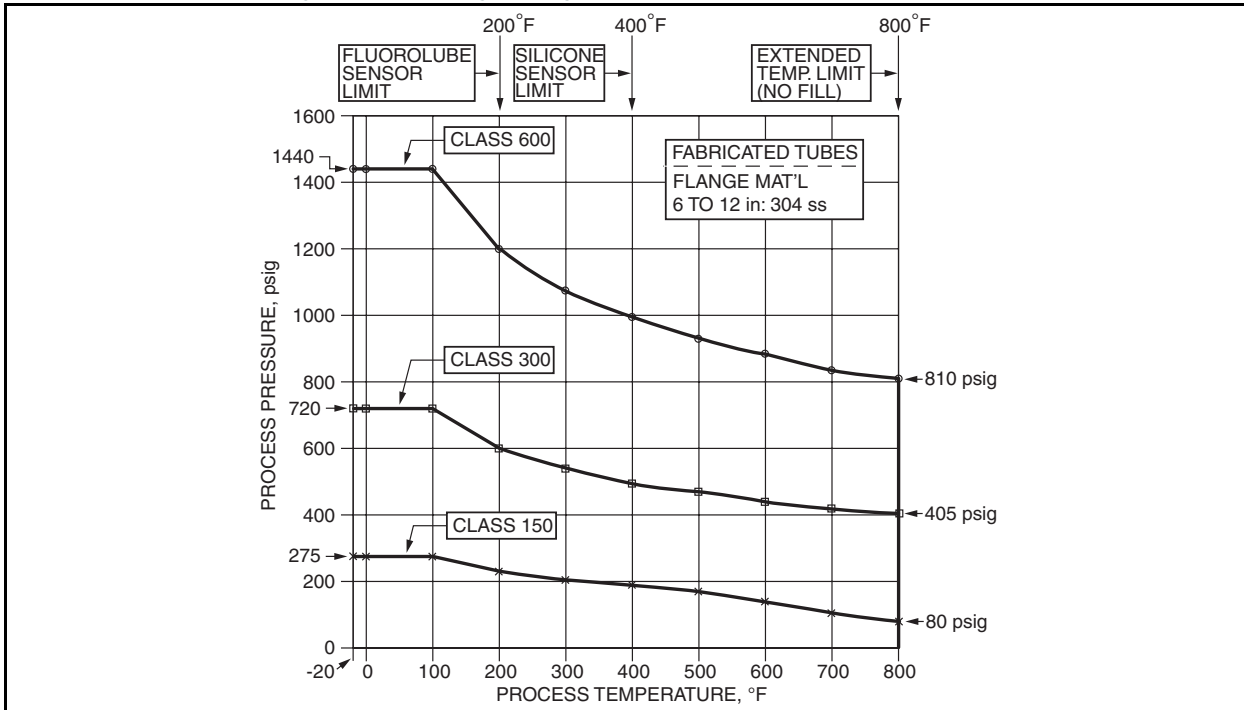

Figure 6. ANSI Flange Ratings; per ASME B16.5; Group 1.1 Materials

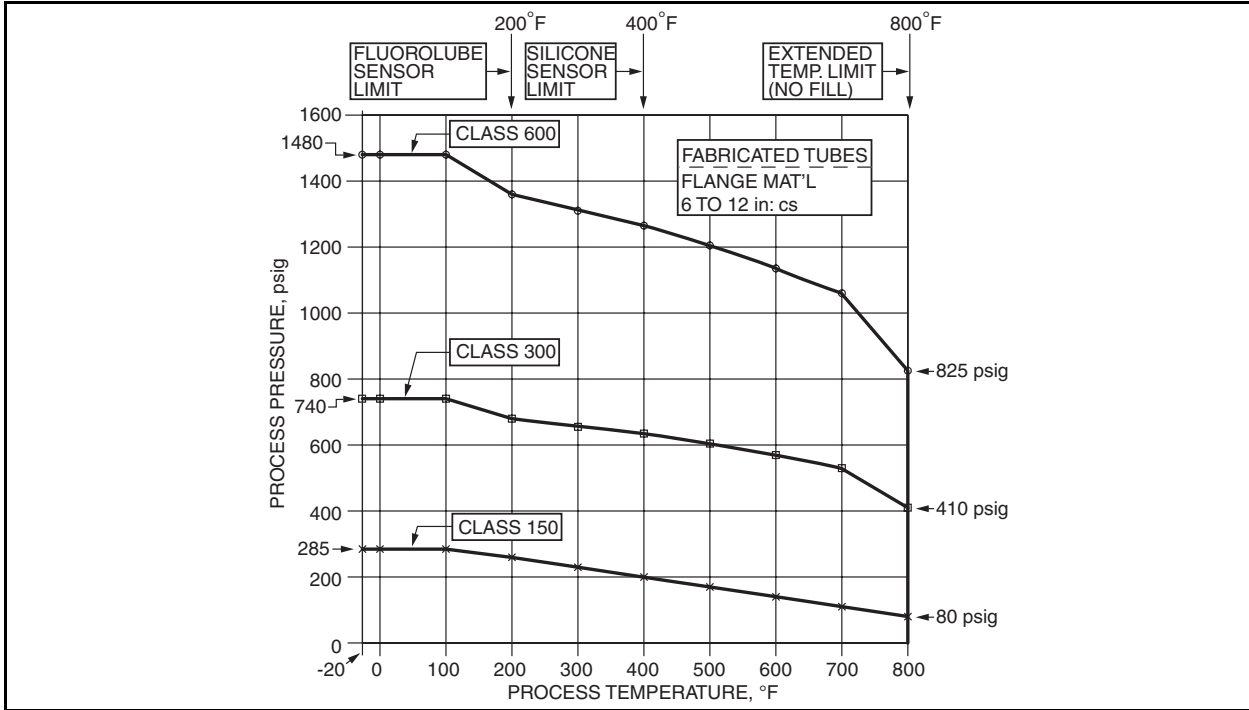

Figure 7. Metric Flange Ratings; per EN 1092-1; Material Group 14E0

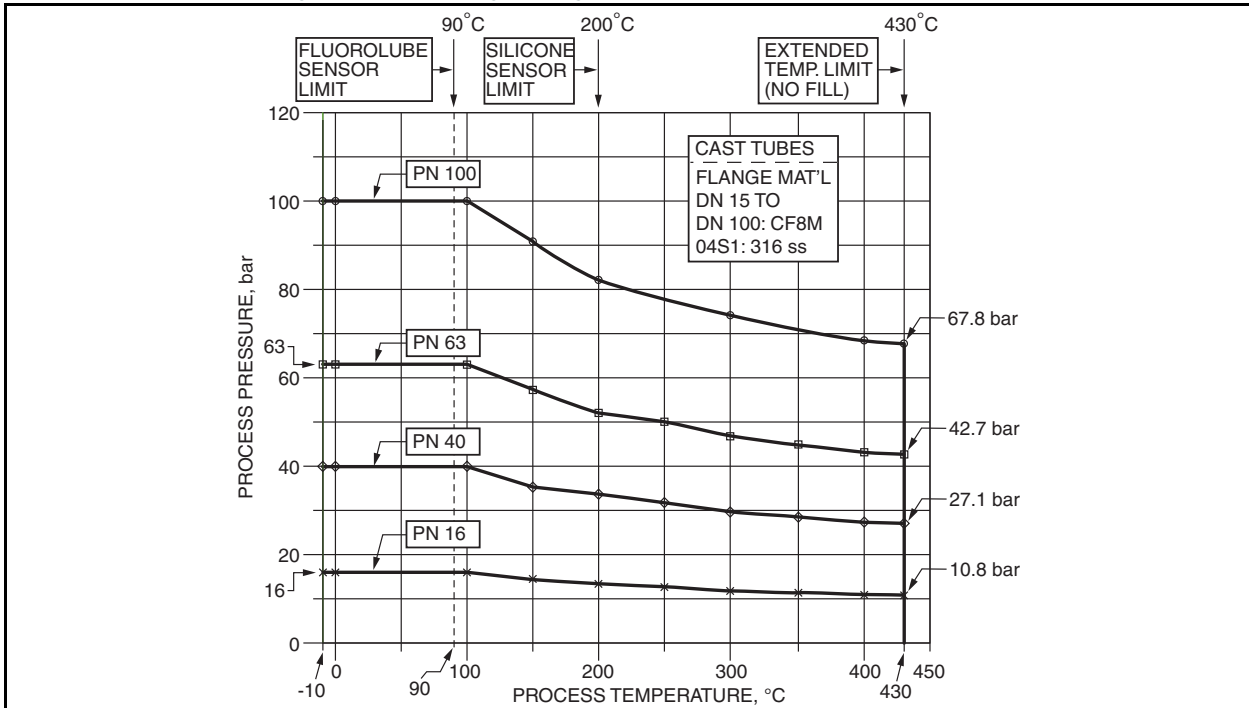

Figure 8. Metric Flange Ratings; per EN 1092-1; Material Group 10E0

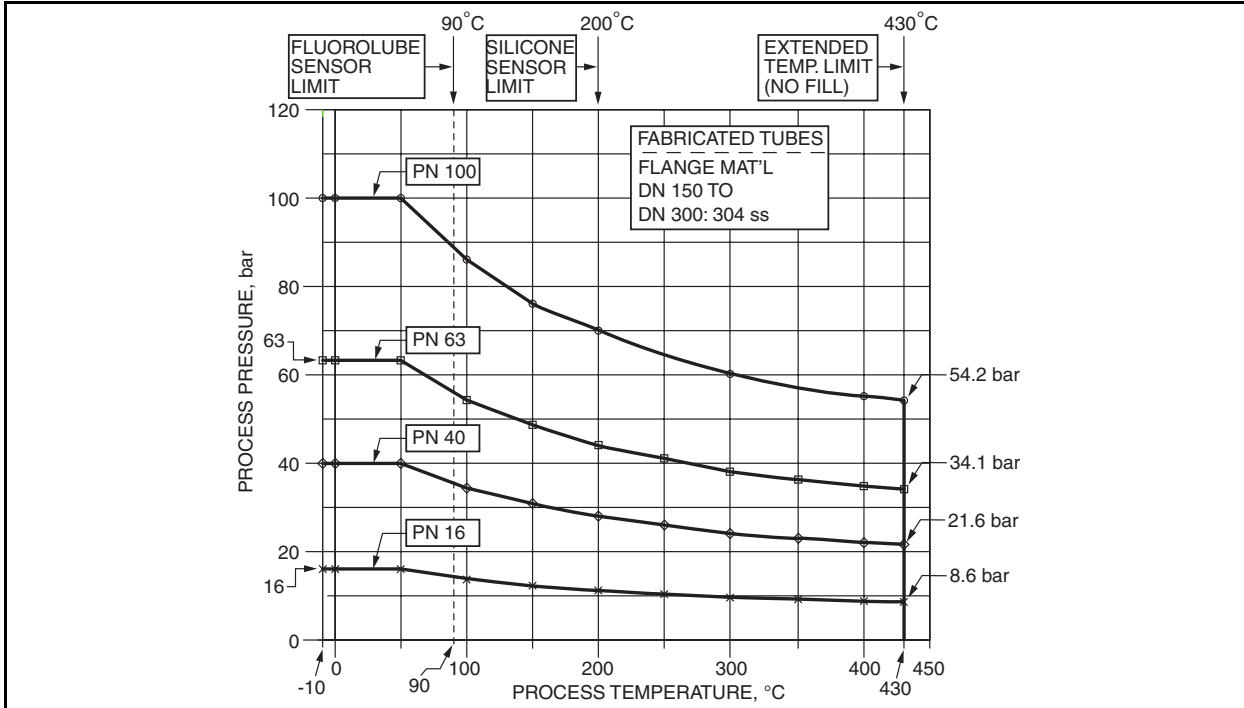

Figure 9. Metric Flange Ratings; per EN 1092-1; Material Group 3E0

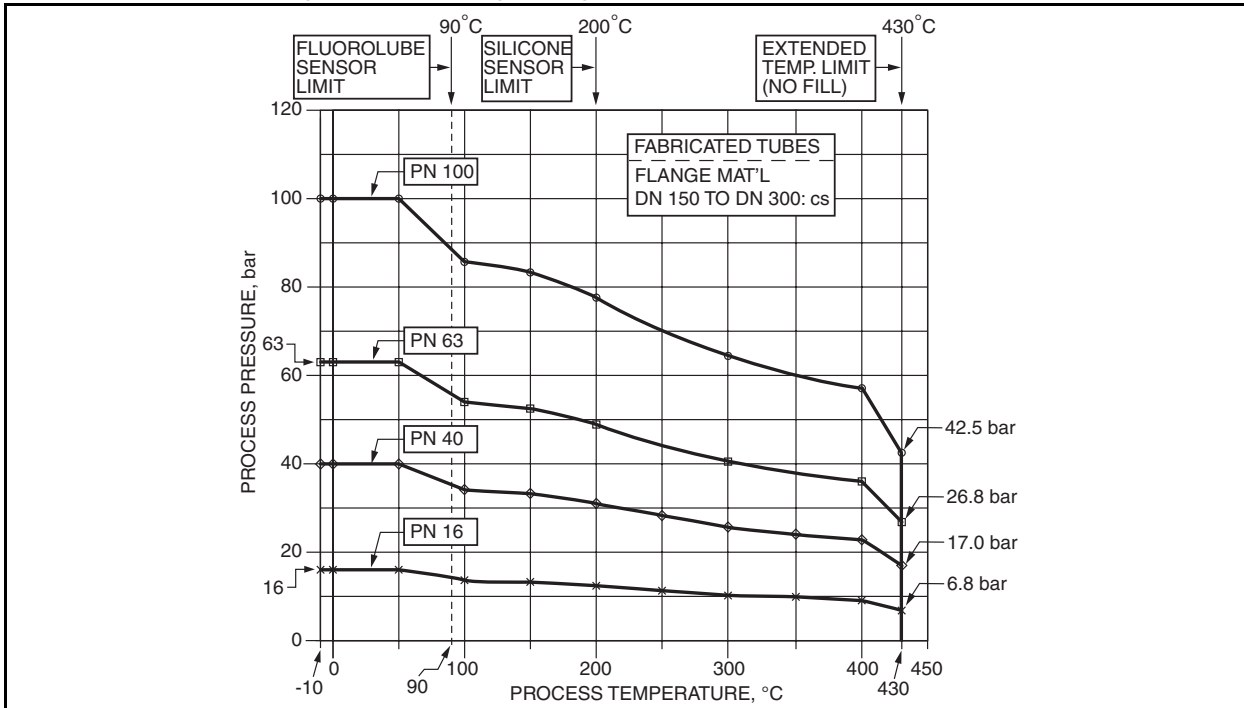
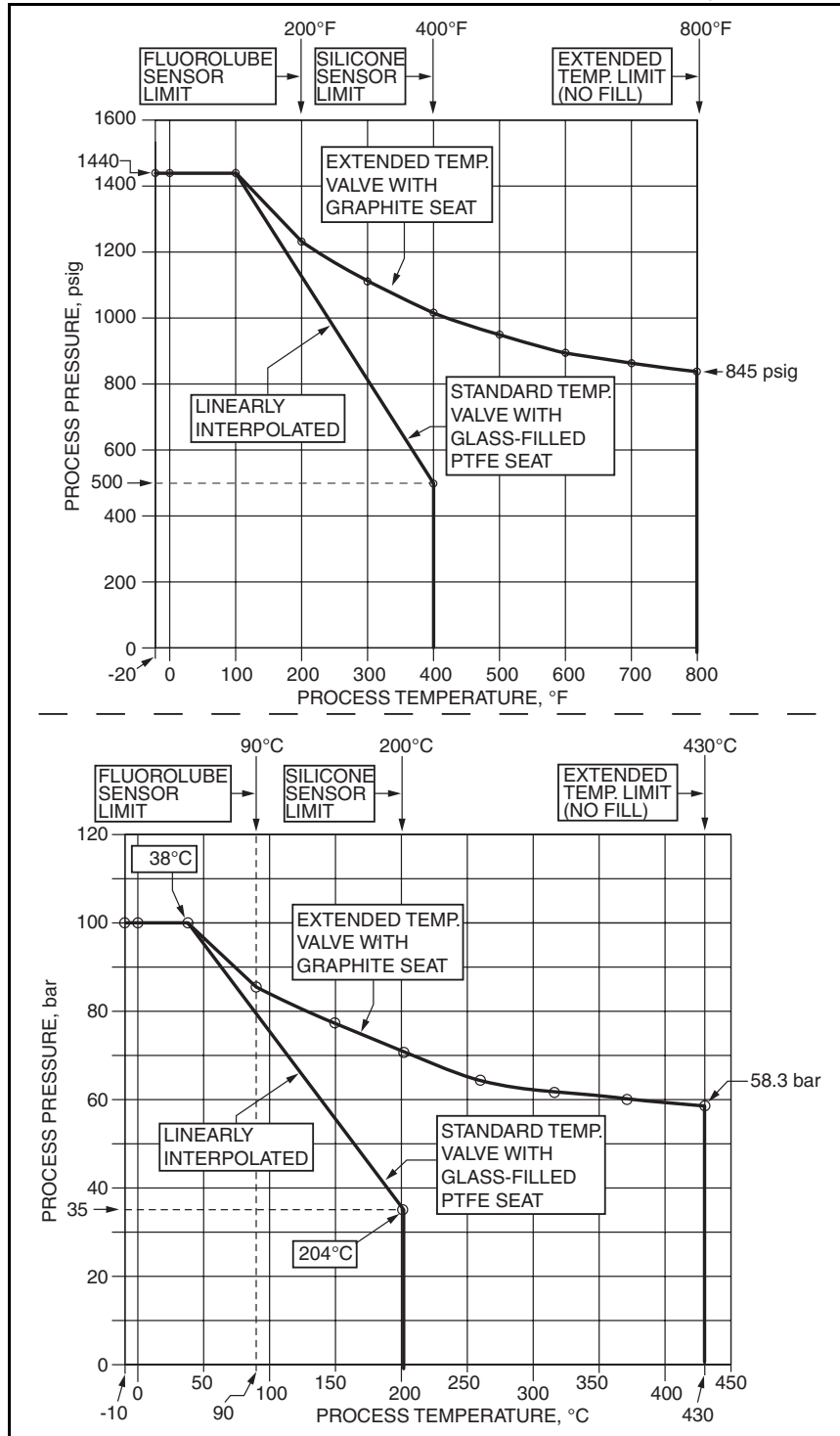

Figure 10. Pressure-Temperature Limits with Isolation Valves; U.S. Customary and Metric Units



PHYSICAL SPECIFICATIONS

See Model Code for options

Process-Wetted Parts - Model 84F**Flowmeter Body, Flanges, and Shedding Bar**

- ▶ 316 ss up to 4 in (DN 100) sizes;
- ▶ 304 ss body and shedder, and cs or ss flange, for sizes >4 in (>DN 100).

Gasket and Flow Dam (sensor seals)

- ▶ Standard Temperature Sensor
 - PTFE gasket and flow dam
- ▶ High Temperature Sensor
 - 316 ss gasket; 316 ss/grafoil flow dam
 - Nickel alloy CW2M (equivalent to Hastelloy® C-4C)⁽³⁾ gasket; nickel alloy CW2M/grafoil flow dam

Process-Wetted Parts - Model 84W**Flowmeter Body and Shedding Bar**

- ▶ 316 ss for all sizes; or
- ▶ Nickel alloy CW2M (equivalent to Hastelloy® C-4C) for 3/4 to 4 in (DN 15 to DN 100) sizes.

Gasket and Flow Dam (sensor seals)

- ▶ Standard Temperature Sensor
 - PTFE gasket and flow dam
- ▶ High Temperature Sensor
 - 316 ss gasket; 316 ss/grafoil flow dam
 - Nickel alloy CW2M (equivalent to Hastelloy® C-4C) gasket; nickel alloy CW2M/grafoil flow dam

Process-Wetted Parts - Model 84S**Flowmeter Body**

- ▶ 316 ss tube

Shedding Bar

- ▶ 316L ss per ASTM 276

Sensor Diaphragm

- ▶ 316L ss

End Connections

- ▶ 316 ss

Electronics Housing and Housing Covers

A two compartment housing separates the electronics from the field connections. Housing and covers are low copper, die-cast aluminum alloy with an epoxy finish. Buna-N O-ring seals are used to seal the housing covers, housing neck, and terminal block.

Dual Measurement Manifold - Model 84F

CF8M stainless steel; pressure and temperature rating of dual manifold same as flowmeter body.

Sensor Capsule Fill Material**84F and 84W (Standard Temperature Range Only)**

- ▶ Silicone or Fluorolube oil fill

84S

- ▶ Food Grade Silicone oil fill

Electronics Module

Printed wiring assemblies (PWAs) are conformally coated for moisture and dust protection.

⁽³⁾ Hastelloy® is a registered trademark of Haynes International, Inc.

PHYSICAL SPECIFICATIONS

Electrical Connections

See Figure 11. Field wires enter through 1/2 NPT or M20 threaded entrances on either side of the electronics housing. Wires terminate under screw terminals and washers on terminal block in the field terminal compartment. Unused entrance conduit entrance holes are plugged to insure moisture and RFI/EMI protection.

Figure 11. Terminal Block

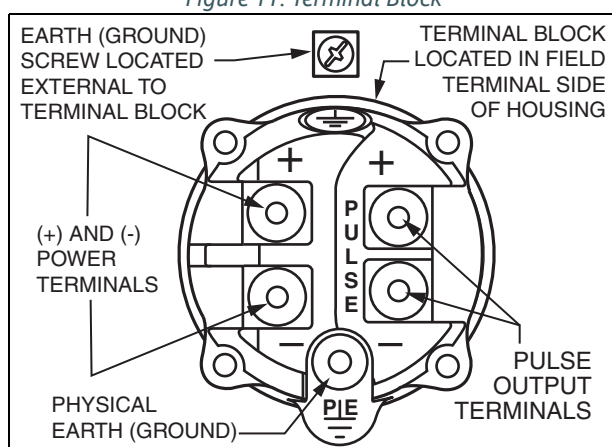

Environmental Protection

The electronics housing has the dusttight and weatherproof rating of IP66 as defined by IEC 60529, and provides the environmental and corrosion resistant protection rating of NEMA 4X.

Flowtube Mounting

Flowtube can be located in a pipeline which may run in any direction from the vertical (upward flow) to the horizontal. A vertical pipeline is preferred for batch operations to provide improved full line assurance. See "RECOMMENDED MOUNTING ARRANGEMENTS" on page 22.

Electronics Housing Mounting

Integral Mounting

Integrally mounting is offered with the 84F and 84W only. The housing can be rotated in 90° increments with respect to the flowtube.

Remote Mounting

Offered for all Flowmeter Models. The housing is mounted to bracket, which in turn attaches to a surface or to a 2 in or DN 50 pipe.

The 84F and 84W housing can be located up to an interconnecting cable length of 50 ft (15.2 m) from the flowtube without loss of low level signal.

The 84S housing is electrically connected to the flowtube with a 15 ft (4.5 m) cable that is integral to the flowtube.

Data Plate

Stainless steel data plate encircles and is secured to the lower part of the electronics housing. Includes Model and Serial Numbers, operating limits, data, factory calibration factor (K-factor), and tag data. An optional Stainless Steel Customer Tag is also offered for additional tag information. See Optional Selections section.

NACE Certification - Models 84F and 84W

The Models 84F and 84W Flowmeters have been designed, and the process-wetted materials selected, to meet the requirements of NACE Standard MR-0175-2003 for use in H₂S Sour Oilfield environments. The design and process-wetted materials also comply with NACE Standard MR-0103-2007 for use in corrosive petroleum refining environments. A NACE compliance certificate is available by selecting the -Q option.

Isolation Manifold and Valve (if specified) for Models 84F and 84W only

- ▶ Valve Body: Grade CF8M stainless steel
- ▶ Valve Ball: 316 ss
- ▶ Valve Seats:
 - Standard Temperature: Glass-Filled PTFE
 - Extended Temperature: Graphite
- ▶ Stem Seal: The valve stem seal meets the external leakage requirements for fire safety per API Standard 607.
- ▶ Valve Handle: Use adjustable wrench.
- ▶ Seat Leakage:
 - Standard Temperature
Class IV – Less than 5 mL/h per MSS-SPG1.
 - High Temperature
Class IV per ANSI/FCI-70.2
- ▶ Flow Velocity Limits: See Table 1.
- ▶ Applications: Can be used with clean liquids, saturated steam, and gases.
- ▶ Limitations: Not recommended for use with superheated steam without insulation, liquids with suspended solids, or volatile fluids.
- ▶ Mounting; See Installation MI.
- ▶ Pressure/Temperature Rating: Refer to Figure 10 for ratings of standard temperature valves with a PTFE seat, and extended temperature valves with a graphite seat.

Dimensions

Refer to DIMENSIONS-NOMINAL section. For further details, refer to the following Dimensional Prints (DPs):

- ▶ DP 019-120 (84F Single Measurement)
- ▶ DP 019-121 (84F Dual Measurement)
- ▶ DP 019-122 (84W)
- ▶ DP 019-123 (84S)

Approximate Weight

See Tables 3 and 4.

Weights shown are approximate and are meant as a guide to the user.

- ▶ Standard temperature flowmeter weights are listed for integrally mounted electronics housings. There is a slight weight difference for high temperature flowmeters (adds about 1 lb (0.5 kg)), or for remote mounted housings (housing replaced by connector head assembly/junction box). The electronics housing itself weighs about 4 lbs (2 kg) and varies slightly depending on whether indicator/configurator, and/or extended housing covers are used.
- ▶ For single measurement flowmeters, add approximately 2 lb (1 kg) if an isolation valve is used.
- ▶ For dual measurement flowmeters (applicable to 84F flowmeters only):
 - Add approximately 9 lb (4 kg) when a manifold without isolation valves is used.
 - Add approximately 15 lb (7 kg) when a manifold with two isolation valves is used.

Table 3. Approximate Weight - Models 84W and 84F

Nominal Line Size		Model 84W Wafer Body		Model 84F Flanged Body (a)	
in	mm	lb	kg	lb	kg
3/4	DN 15	5	2.3	9	4.1
1	DN 25	6	2.7	11	5
1 1/2	DN 40	7	3.2	14	6.5
2	DN 50	10	4.5	18	8
3	DN 80	18	8.0	30	14
4	DN 100	25	11.5	45	20
6	DN 150	35	16	70	30
8	DN 200	60	27	125	57
10	DN 250	Not Available	Not Available	190	90
12	DN 300	Not Available	Not Available	260	120

(a) The weights listed are for the 84F with ANSI Class 150 flanges.

Table 4. Approximate Weight - Model 84S

Nominal Line Size		Flowmeter Description	Approximate Weight with Connections C, M, R, T, U (a)	
in	mm		lb	kg
2	DN 50	Body and Cable	1.6	0.72
		Housing and Bracket	6.5	4.1
		Total	8.1	4.8
3	DN 80	Body and Cable	2.5	1.1
		Housing and Bracket	6.5	4.1
		Total	9	5.2

(a) Connections C, M, R, T, and U are fittings, couplings, and Tri-clamp type connections. See Model Code.

PRODUCT SAFETY SPECIFICATIONS

Pressure Safety

Designed to withstand pressure within ANSI/ASME B16.5 Class 150, 300, or 600 flange ratings, and metric EN 1092-1 PN 16, PN 40, PN 63, or PN 100 flange ratings. See Figures 4 through 10.

For 84W Flowmeters, the flowtube face outside diameter is designed to center between ANSI Class 150 flanges. For other flange ratings, centering spacers are provided.

For the 84S Flowmeter, refer to “Static Pressure Limits” on page 11 in the Functional Specifications section.

Personnel and Electrical Fire Safety

This device is designed to be a minimum fire hazard by using low energy power and adequate insulation and separation of electrical circuits. The required standards of worldwide testing agencies such as FM, CSA, and OSHA have been fulfilled.

ELECTRICAL SAFETY SPECIFICATIONS

The Model 84 has been designed to meet the electrical safety descriptions listed below. For detailed information, or status of the testing laboratory approval/certification, contact Invensys.

With intrinsically safe approvals and certifications with a 24 V dc supply, an active barrier is required.

Refer to MI 019-177 for FM and CSA Connection Diagrams; refer to MI 019-179 for ATEX and IECEx Safety Information.

Agency, Types of Protection, and Area Classification	Application Conditions	Elect. Safety Design Code
ATEX Intrinsically safe: II 1G; II 2D; Ex ia IIC T4 Ga Ex tb IIIC T103°C Db	Sira 06ATEX2067X Integrally mounted or remote mounted (electronics and junction box). Temperature Class T4; Ta = -40° to +80°C	E
ATEX Flameproof: II 2/1 (1) G; II 2D Ex d [ia Ga] ia IIC T4 Gb; Ex tb IIIC T85°C Db	Sira 06ATEX2067X Integrally mounted electronics. Temperature Class T4; Ta = -20° to +80°C	H
ATEX Flameproof: II 2/1 (1) G; II 2D Ex d [ia Ga] IIC T4 Gb; Ex tb IIIC T85°C Db	Sira 06ATEX2067X Electronics housing of remote mounted version. Temperature Class T4; Ta = -20° to +80°C	H
CSA Intrinsically safe: Class I, II, III, Div. 1, Groups A, B, C, D, E, F, and G. Ex ia IIC T4	Temperature Class T4; Ta = -40° to +80°C	C
CSA Explosionproof with Intrinsically Safe sensor connections: Class I, Div. 1, Groups A, B, C, and D; Class II, Div 1, Groups E, F, and G; Class III; [Ex ia]; T5; Ex d [ia] IIC T5 Dust-ignitionproof for Class II, Div. 1, Groups E, F, and G; Class III, Div. 1 Also Zone certified Ex d [ia] IIC.	Temperature Class T5; Ta = 60°C Temperature Class T5; Ta = -40° to +80°C	D
CSA Class I, Division 2: Class I, Div. 2, Groups A, B, C, and D; Class II, Div. 2, Groups E, F and G; Class III.	Temperature Class T4; Ta = 80°C	M

Agency, Types of Protection, and Area Classification	Application Conditions	Elect. Safety Design Code
FM Intrinsically safe: Class I, II, III, Div. 1, Groups A, B, C, D, E, F, G; T4 Class I Zone 0 AEx ia IIC T4	Temperature Class T4; Ta = 80°C	F
FM Explosionproof with Intrinsically Safe sensor connection: Class I, II, III, Div. 1, Groups B, C, and D; T5 Dust-ignitionproof for Class II, III, Div. 1, Groups E, F, and G	Temperature Class T5; Ta = 85°C	G
FM Nonincendive: Class I, II, Div. 2, Groups A, B, C, and D; T4 Class II, III, Div. 2, Groups F and G	Temperature Class T4; Ta = 80°C	K
IECEX Intrinsically safe: Ex ia IIC T4 Ga; Ex tb IIIC T103°C Db	IECEX SIR 06.0020X Temperature Class T4; Ta = -40° to +80°C	L
IECEX Flameproof: Ex d [ia Ga] ia IIC T4 Gb Ex tb IIIC T85°C Db	IECEX SIR 06.0020X Integrally mounted electronics. Temperature Class T4; Ta = -20° to +80°C	B
IECEX Flameproof: Ex d [ia Ga] IIC T4 Gb Ex tb IIIC T85°C Db	IECEX SIR 06.0020X Electronic housing of remote mounted version. Temperature Class T4; Ta = -20° to +80°C	B
NEPSI Intrinsically safe, Zone 0, Ex ia IIC	Temperature Class T4; Ta = -40° to +80°C	R
NEPSI Flameproof, Zone 1, Ex d IIC (except acetylene)	Temperature Class T5; Ta = -40° to +85°C	S
Unit with CE mark and PED controls and records		Y
Unit does not have CE mark; not to be installed in European Union (EU) countries		Z

RECOMMENDED MOUNTING ARRANGEMENTS

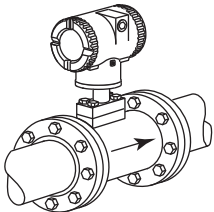
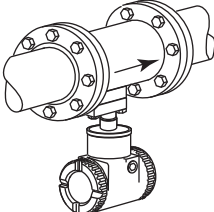
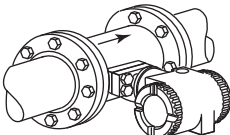
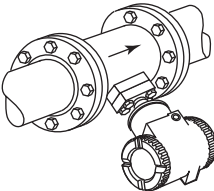
Flowmeter Mounting Arrangements Model 84F Single Measurement Flowmeter Shown (Dual Measurement Flowmeters follow same arrangements)		Flowmeter for Use With:			
		Liquid	Gas	Saturated Steam	Superheated Steam
	Housing Above Pipe; Isolation Valve and Dual Measurement Flowmeter NOT Used.	Yes (a)	Yes	No	Yes (b)
	Housing Above Pipe; Isolation Valve and Dual Measurement Flowmeter CAN be Used.	No (c)	Yes	No	Yes (b)
	Housing Below Pipe.	Yes (d) (e) (f)	Yes (e)	Yes	Yes (b)
	Housing to Side of Pipe.	Yes	Yes	No	Yes (b)
	Housing to Side and Below Pipe.	Yes (f)	Yes	No	Yes (b)

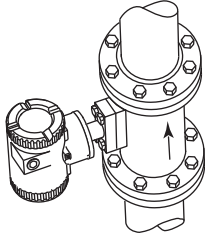
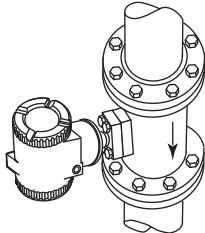
Flowmeter Mounting Arrangements (Continued) Model 84F Single Measurement Flowmeter Shown (Dual Measurement Flowmeters follow same arrangements)		Flowmeter for Use With:			
		Liquid	Gas	Saturated Steam	Superheated Steam
	Vertical Pipe, Flow upward.	Yes	Yes	No	Yes (b)
	Vertical Pipe, Flow Downward.	Yes (g)	Yes	No	Yes (b)

- (a) Possibility of temporary start-up error due to trapped air.
- (b) Requires adequate insulation.
- (c) Not recommended for liquids with isolation valve.
- (d) Best choice when errors due to start-up cannot be tolerated.
- (e) Recommended only for clean fluids.
- (f) Preferred for liquids with isolation valve.
- (g) Not preferred; must maintain full pipe with no voids in fluid.

OPTIONAL SELECTIONS AND ACCESSORIES

Options -B, -D, -E, -G: Cable Assembly to Remote Electronics Housing - 84F and 84W

When selecting Codes R or W for a Remote Mounted Housing, a cable length must be selected. Four cable lengths are offered as follows:

Option	Cable Length
-B	20 ft (6 m)
-D	30 ft (9 m)
-E	40 ft (12 m)
-G	50 ft (15 m)

Option -H: Cleaning for Oxygen or Chlorine Gas Service - 84F and 84W

Process wetted parts are cleaned for oxygen or chlorine service in compliance with Compressed Gas Association's CGA-4.1 and ASTM G93. Cleaning is not offered when an isolation valve, or dual measurement or extended temperature meters are selected.

Option -J: Gold Plated Sensor - 84F and 84W

This option is recommended for H₂ (Hydrogen) processes.

Options -L, -M, -Q: Foxboro Certificates of Conformance and Compliance

Three material certificates are offered:

- ▶ Option -L provides a certificate of compliance to the specifications of the Invensys/Foxboro Quality System, which conforms to ISO 9001.
- ▶ Option -M is a certification of material for process wetted metal (conforms to BS EN 10204 3.1).
- ▶ Option -Q certifies that the process wetted materials for Models 84F and 84W comply with NACE Standards MR-0175-2003 and MR-0103-2007.

Option -N: Certified Calibration Certificate

A calibration and pressure test sheet comes standard with each meter. Option -N provides a certified version of the standard calibration and pressure test sheet.

Options -F, -V, -X: Welding Certificates – With Flanged Body Flowtubes Only - 84F

Three certificates are available. Option -F certifies that the fabrication of 6 to 12 in (150 to 300 mm) flowtubes by welders is to ASME Boiler Code, Section IX. Option -V provides radiographic examination and certification of circumferential welds (not available with ANSI Class 150 or Metric PN 16 flanges). And Option -X certifies that welding is per ASME Boiler Code and Radiographic Examination (except as noted for Option -F).

Option -P: Cable Connector - Hawke-Type Cable Gland - 84F and 84W

Brass cable gland with 1/2 NPT external thread. Provides support for field cable. Ensure that this cable connector is qualified to meet the electrical safety specification selected. See Electrical Safety Specification section. Available with Electronics Housing Codes T and R only (1/2 NPT).

Option -R: Cable Connector - PG11 Cable Gland - 84F and 84W

A PG11 cable gland with 1/2 NPT external thread. Provides strain relieved support for field cable. The PG11 is for cable diameters from 8 to 12 mm. Ensure that this cable connector is qualified to meet the electrical safety specification selected. See Electrical Safety Specification section. Available with Electronics Housing Codes T and R only (1/2 NPT).

Option -T: Conduit Fitting - 84F and 84W

A conduit fitting is available with Remote Mounting Code R only. It is provided when conduit is used to enclose the cable between the flowtube body and remote transmitter. Both ends of the fitting are 1/2 NPT and interconnect the conduit and transmitter at the housing and flowtube ends.

**AS Code MTS: Stainless Steel Customer Tag
Accessory**

A 40 x 90 mm (1.5 x 3.5 in) stainless steel tag is optionally available for customer data that does not fit on the standard data plate. It is fastened to housing with wire and accommodates 10 lines of data with 40 characters/spaces per line. Customer tag data must be submitted to Invensys.

Bolting Kits – Wafer Body Flowtubes Only

Sets of carbon steel studs and nuts which conform to line size, and ANSI or DIN size and rating, are offered in 3/4 to 4 in line sizes for ANSI flanges, and DN 50 to DN 100 mm line sizes for DIN flanges. Refer to the following tables to select the kit and part number required.

Table 5. ANSI Bolting Kits - Part Numbers

Size	Cl. 150	Cl. 300	Cl. 600
3/4 in	D0148ZF	D0148ZJ	D0148ZJ
1 in	D0148ZF	D0148ZJ	D0148ZJ
1 1/2 in	D0148ZF	D0148ZK	D0148ZS
2 in	A2044HB	A2044HB (a)	A2044HC (a)
3 in	A2044HC	A2044HD	A2044HD
4 in	A2044HC (a)	A2044HD	A2044HE

(a) Two kits required.

Table 6. Metric Bolting Kits - Part Numbers

Size	PN 16	PN 40	PN 64	PN 100
DN 50	N/A	D0148ZU	N/A	N/A
DN 80	N/A	D0148ZZ (a)	N/A	N/A
DN 100	L0114NT	L0114NT	N/A	N/A

(a) Two kits required.

MODEL CODE - 84F (FLANGED BODY) LOW POWER VORTEX FLOWMETER

Description	Model
Intelligent Vortex Flowmeter – Flanged Body	84F
Electronics Version	
Intelligent Electronics, LOW POWER, HART Protocol, with Pulse Output (a)	-L
Intelligent Electronics, LOW POWER, HART Protocol, without Pulse Output (a)	-M
Nominal Line Size	
3/4 in (DN 15) Line Size	3Q
1 in (DN 25) Line Size	01
1 1/2 in (DN 40) Line Size	1H
2 in (DN 50) Line Size	02
3 in (DN 80) Line Size	03
4 in (DN 100) Line Size	04
6 in (DN 150) Line Size	06
8 in (DN 200) Line Size	08
10 in (DN 250) Line Size	10
12 in (DN 300) Line Size	12
Body, Flange, and Shedder Bar Material	
Sizes 3Q to 04; Cast Body/Flange and Shedder (except Code 04S1); CF8M Material. Size 04S1; Fabricated from 316 ss Tubing and Flanges.	S
Sizes 06 to 12; Body Fabricated from 304 ss Tubing with 304 ss Flanges. Sizes 06 to 12; Body Fabricated from 304 ss Tubing with Carbon Steel (A105) Flanges.	K

MODEL CODE - 84F (FLANGED BODY) LOW POWER VORTEX FLOWMETER (CONTINUED)

Description	Model
End Connections and Flange Rating	
Description	Used with Line Sizes
ANSI Class 150 Flange, ASME B16.5	All line sizes
ANSI Class 300 Flange, ASME B16.5	All line sizes
ANSI Class 600 Flange, ASME B16.5	3Q through 08 only
Metric PN 16 Flange, EN1092-1, RF, Type D Nut Groove	06 through 12 only
Metric PN 40 Flange, EN1092-1, RF, Type D Nut Groove	3Q through 08 only
Metric PN 63 Flange, EN1092-1, RF, Type D Nut Groove	02 through 12 only (b)
Metric PN 100 Flange, EN1092-1, RF, Type D Nut Groove	3Q through 08 only
Metric PN 16 Flange, EN1092-1, RF, Finish Type B1	06 through 12 only
Metric PN 40 Flange, EN1092-1, RF, Finish Type B1	All line sizes
Metric PN 63 Flange, EN1092-1, RF, Finish Type B2	02 through 12 only (c)
Metric PN 100 Flange, EN1092-1, RF, Finish Type B2	3Q through 08 only
	1
	2
	3
	5
	6
	7
	8
	D
	F
	G
	H
Single or Dual Measurement; Isolation Valve and Manifold	
Single Measurement; No Isolation Valve	S
Dual Measurement; Manifold with no Isolation Valves	D
Single Measurement; Manifold with one Isolation Valve; CF8M Stainless Steel	K
Dual Measurement; Manifold with two Isolation Valves; CF8M Stainless Steel	L
Sensor Fill, Temperature Range, and Material	
Standard Temperature Range (with Fill Fluid)	
Fluorolube Fill, 0 to 200°F (-20 to +90°C), Nickel Alloy CW2M (equivalent to Hastelloy® C-4C)	D
Fluorolube Fill, 0 to 200°F (-20 to +90°C), Stainless Steel Type CF3M	F
Silicone Fill, 0 to 400°F (-20 to +200°C), Nickel Alloy CW2M (equivalent to Hastelloy® C-4C)	R
Silicone Fill, 0 to 400°F (-20 to +200°C), Stainless Steel Type CF3M	S
Extended Temperature Range (No Fill Fluid) (d)	
Unfilled, 400 to 800°F (200 to 430°C), Nickel Alloy CW2M (equivalent to Hastelloy® C-4C)	C
Unfilled, 400 to 800°F (200 to 430°C), Stainless Steel Type CF3M	T
Electronics Housing Mounting, Material, and Conduit Connections	
Mounted to Flowtube; Aluminum Housing; 1/2 NPT Conduit Connections	T
Mounted to Flowtube; Aluminum Housing; M20 Conduit Connections	V
Remote Mounted; Aluminum Housing; 1/2 NPT Conduit Connections (e)	R
Remote Mounted; Aluminum Housing; M20 Conduit Connections (e)	W
Local Digital Indicator/Configurator	
No Digital Indicator/Configurator	N
Full Function Digital Indicator/Configurator	J
Electrical Safety (refer to Electrical Safety Specifications section for details)	
ATEX intrinsically Safe	E
ATEX flameproof	H
CSA intrinsically safe	C
CSA Division 2	M
CSA explosionproof	D
FM intrinsically safe	F
FM nonincendive	K
FM explosionproof	G
IECEX intrinsically safe	L
IECEX flameproof	B
NEPSI intrinsically safe	R
NEPSI flameproof	S
No Agency Electrical Certifications; with CE mark, PED Controls and Records	Y
No Agency Certifications; no CE mark; Units not to be installed in European Union (EU) countries	Z

MODEL CODE - 84F (FLANGED BODY) LOW POWER VORTEX FLOWMETER (CONTINUED)

<u>Description</u>	<u>Model</u>
Optional Selections	
Cable Length Selection for Remote Electronics Housing	
20 ft (6 m) Cable to Connect to Remote Electronics Housing	-B
30 ft (9 m) Cable to Connect to Remote Electronics Housing	-D
40 ft (12 m) Cable to Connect to Remote Electronics Housing	-E
50 ft (15 m) Cable to Connect to Remote Electronics Housing	-G
Cleaning - Oxygen/Chlorine Service	
Cleaning of Process Wetted Parts per Compressed Gas Association's CGA G-4.1 and ASTM G93	-H
- Available only with Body/Flange/Sheeder Material Code S	
- Not available for Sizes -10 and -12 or with Isolation Valve Codes D, K, and L	
- Not available with Extended Temperature Codes C and T	
Sensor Plating	
Gold Plated Sensor	-J
Foxboro Certificates of Compliance/Conformance	
Standard Certificate of Compliance	-L
Material Certification of Process Wetted Metal (Conforms to BS EN 10204 3.1)	-M
Process Wetted Parts Comply with NACE Standards MR-0175-2003 and MR-0103-2007	-Q
Calibration Certificate	
Foxboro Calibration and Pressure Test Certified Copy	-N
Cable Connectors – with Electronics Housing Codes T and R only (1/2 NPT)	
Hawke-Type Cable Gland (available only with electrical safety codes Y and Z)	-P
PG11 Cable Gland, Trumpet Shaped (not with explosionproof/flameproof certifications)	-R
Conduit Fitting	
Adapter for use with 1/2 NPT conduit (Available with Remote Mounted Housing Code R only)	-T
Welding Certificate (Size Codes 06 through 12 only)	
Welding Certified to ASME Boiler Code (f)	-F
Radiographic Examination (X-Ray) of Flange Welds (f)	-V
Welding Certified to ASME Boiler and Radiographic Examination (X-Ray) of Flange Welds (g)	-X
Instruction Manual	
Detailed Instruction Manual in place of Universal MI 019-146	-C
Examples: 84F-L02S1SDTNK-M; 84F-M06K7DCRJC-GQNT	

- (a) The LOW POWER Vortex Flowmeter is not available with a 4 to 20 mA output.
- (b) For 3Q, 01, and 1H line sizes, select End Connection Code 8.
- (c) For 3Q, 01, and 1H line sizes, select End Connection Code H.
- (d) Application ALERT: For Extended Temperature Range sensors used in hazardous or volatile gas applications, there is the potential of fugitive emissions to occur through the sensor vented restrictor if the sensor diaphragm were to fail.
- (e) With remote mounted electronics housing, you must also select Optional Cable Length -B, -D, -E, or -G.
- (f) Not available with End Connection Codes 1, 5, and D for 6 and 8 inch sizes.
- (g) Not available with End Connection Codes 1 and 5 for 6 and 8 inch sizes.

MODEL CODE - 84W (WAFER BODY) LOW POWER VORTEX FLOWMETER

Description	Model
Intelligent Vortex Flowmeter – Wafer Body	84W
Electronics Type	
Intelligent Electronics, LOW POWER HART Protocol, with Pulse Output (a)	-L
Intelligent Electronics, LOW POWER HART Protocol, without Pulse Output (a)	-M
Nominal Line Size	
3/4 in (DN 15) Line Size	3Q
1 in (DN 25) Line Size	01
1 1/2 in (DN 40) Line Size	1H
2 in (DN 50) Line Size	02
3 in (DN 80) Line Size	03
4 in (DN 100) Line Size	04
6 in (DN 150) Line Size	06
8 in (DN 200) Line Size	08
Body and Shedder Bar Material	
ASTM A351-CF8M (316 ss) Cast Body and Shedder	S
ASTM A494-CW2M Nickel Alloy (equivalent to Hastelloy® C-4C) Cast Body and Shedder; with Size Codes 3Q to 04 only	H
Mounting and Centering System	
Centering for	
ANSI Class 150, 300, and 600 Flanges	Used with Line Sizes
Metric PN 16 Flange	3Q through 04 only
Metric PN 40 Flange	01 through 03 only
Metric PN 63 and PN 100 Flanges	01 through 03 and 06 and 08 only
ANSI Class 600 Flange	All line sizes
Metric PN 16 Flange	06 and 08 only
Metric PN 40 Flange	04, 06, and 08 only
Metric PN 16 and PN 40 Flanges	04 only
	3Q only
	1
	3
	4
	5
	9
Isolation Valve and Manifold	
No Isolation Valve or Manifold	S
Manifold with Isolation Valve, ASTM A 351-CF8M Stainless Steel (316 ss)	K
Sensor Fill, Temperature Range, and Material	
Standard Temperature Range (with Fill Fluid)	
Fluorolube Fill, 0 to 200°F (-20 to +90° C), Nickel Alloy CW2M (equivalent to Hastelloy® C-4C)	D
Fluorolube Fill, 0 to 200°F (-20 to +90° C), Stainless Steel Type CF3M	F
Silicone Fill, 0 to 400°F (-20 to +200° C), Nickel Alloy CW2M (equivalent to Hastelloy® C-4C)	R
Silicone Fill, 0 to 400°F (-20 to +200° C), Stainless Steel Type CF3M	S
Extended Temperature Range (No Fill Fluid) (b)	
Unfilled, 400 to 800°F (200 to 430° C), Nickel Alloy CW2M (equivalent to Hastelloy® C-4C)	C
Unfilled, 400 to 800°F (200 to 430° C), Stainless Steel Type CF3M	T
Electronics Housing Mounting, Material, and Conduit Connections	
Integrally Mounted to Flowtube; Aluminum Housing, 1/2 NPT Conduit Connection	T
Integrally Mounted to Flowtube; Aluminum Housing, M20 Conduit Connection	V
Remote Mounted; Aluminum Housing, 1/2 NPT Conduit Connection (c)	R
Remote Mounted; Aluminum Housing, M20 Conduit Connection (c)	W
Local Digital Indicator/Configurator	
No Digital Indicator/Configurator	N
Full Function Digital Indicator/Configurator	J

MODEL CODE - 84W (WAFER BODY) LOW POWER VORTEX FLOWMETER (CONTINUED)

<u>Description</u>	<u>Model</u>
Electrical Safety (refer to Electrical Safety Specifications section for details)	
ATEX intrinsically Safe	E
ATEX flameproof	H
CSA intrinsically safe	C
CSA Division 2	M
CSA explosionproof	D
FM intrinsically safe	F
FM nonincendive	K
FM explosionproof	G
IECEX intrinsically safe	L
IECEX flameproof	B
NEPSI intrinsically safe	R
NEPSI flameproof	S
No Agency Electrical Certifications; with CE mark, PED Controls and Records	Y
No Agency Certifications; no CE mark; Units not to be installed in European Union (EU) countries	Z
Optional Selections	
Cable Length Selection for Remote Electronics Housing	
20 ft (6 m) Cable to Connect to Remote Electronics Housing	-B
30 ft (9 m) Cable to Connect to Remote Electronics Housing	-D
40 ft (12 m) Cable to Connect to Remote Electronics Housing	-E
50 ft (15 m) Cable to Connect to Remote Electronics Housing	-G
Cleaning - Oxygen/Chlorine Service	
Cleaning of Process Wetted Parts per Compressed Gas Association's CGA G-4.1 and ASTM G93 Not available with Isolation Valve Code K, or Sensor Codes C and T	-H
Sensor Plating	
Gold Plated Sensor	-J
Foxboro Certificates of Compliance/Conformance	
Standard Certificate of Compliance	-L
Material Certification of Process Wetted Metal (Conforms to BS EN 10204 3.1)	-M
Process Wetted Parts Comply with NACE Standards MR-0175-2003 and MR-0103-2007	-Q
Foxboro Calibration Certificate	
Calibration and Pressure Test Certified Copy	-N
Cable Connectors – with Electronics Housing Codes T and R only (1/2 NPT)	
Hawke-Type Cable Gland (available only with electrical safety codes Y and Z)	-P
PG11 Cable Gland, Trumpet Shaped (not with explosionproof/flameproof certifications)	-R
Conduit Fitting	
Adapter for use with 1/2 NPT conduit (Available with Remote Mounted Housing Code R only)	-T
Instruction Manual	
Detailed Instruction Manual in place of Universal MI 019-146	-C
Examples: 84W-M02S1SRRJF-D; 84W-L04H4SRTNF-CL	

- (a) The LOW POWER Vortex Flowmeter is not available with a 4 to 20 mA output.
- (b) Application ALERT: For Extended Temperature Range sensors used in hazardous or volatile gas applications, there is the potential of fugitive emissions to occur through the sensor vented restrictor if the sensor diaphragm were to fail.
- (c) With remote mounted electronics housing, you must also select Optional Cable Length -B, -D, -E, or -G.

MODEL CODE - 84S (SANITARY) LOW POWER VORTEX FLOWMETER

Description	Model
Intelligent Sanitary Vortex Flowmeter	84S
Electronics Type	
Intelligent Electronics, LOW POWER, HART Protocol, with Pulse Output (a)	-L
Intelligent Electronics, LOW POWER, HART Protocol, without Pulse Output (a)	-M
Nominal Line Size	
2 in (DN 50), Stainless Steel Tubing	02
3 in (DN 80), Stainless Steel Tubing	03
End Connection Type (Welded to Flowmeter Body) (b)	
3-A I-Line Fitting, Mates with Cherry Burrell 15 WI or Equivalent	C
ANSI Class 150 RF Flange (c)	F
Metric (DIN 11851) Coupling with External Knuckle Thread, per DIN 405, Part 1	M
RJT Coupling per BS 1864, with External Whitworth Thread, 6 TPI	R
3-A Tri-Clamp Type Quick-Disconnect Ferrule, Mates with Tri-Clover 14 WMP, or equivalent	T
ISS (ISO 2853) Coupling with External Trapezoidal Thread, 8 TP	U
Local Digital Indicator/Configurator	
No Digital Indicator/Configurator	N
Full Function Digital Indicator/Configurator	J
Electronics Housing Material and Conduit Connections	
Remote Mounted; Aluminum Housing; 1/2 NPT Conduit Connections	R
Remote Mounted; Aluminum Housing; M20 Conduit Connections	W
Electrical Safety (refer to Electrical Safety Specifications section for details)	
ATEX intrinsically Safe	E
ATEX flameproof	H
CSA intrinsically safe	C
CSA Division 2	M
CSA explosionproof	D
FM intrinsically safe	F
FM nonincendive	K
FM explosionproof	G
IECEX intrinsically safe	L
IECEX flameproof	B
NEPSI intrinsically safe	R
NEPSI flameproof	S
No Agency Electrical Certifications; with CE mark, PED Controls and Records	Y
No Agency Certifications; no CE mark; Units not to be installed in European Union (EU) countries	Z
Optional Selections	
Foxboro Certificates of Compliance/Conformance	
Standard Certificate of Compliance	-L
Material Certification of Process Wetted Metal (Conforms to BS EN 10204 3.1)	-M
Foxboro Calibration Certificate	
Calibration and Pressure Test Certification	-N
Instruction Manual	
Detailed Instruction Manual in place of Universal MI 019-145	-C
Example: 84S-L02CJRF-LN	

- (a) The LOW POWER Vortex Flowmeter is not available with a 4 to 20 mA output.
- (b) Mating end connections, gaskets, and clamps to be supplied by the user.
- (c) The ANSI Class 150 RF flange is not available if 3-A compliance is required.

SUGGESTED RFQ SPECIFICATIONS

The manufacturer shall provide low power, field-mounted vortex flowmeters featuring digital signal processing techniques capable of accurately measuring liquid, gas, or steam flows. The specifications for these meters are as follows:

Communication Protocol:	HART
Outputs:	HART digital, with or without pulse output.
Configuration:	Local configuration with the LCD indicator; remote configuration with the HART communicator, or PC-based configurator.
Accuracy:	0.5% of reading in liquids, 1.0% of reading in gas and steam.
Internal Flow Totalizer:	Standard.
Sensor:	Replaceable without meter recalibration required - 84F and 84W only.
EMI and RFI:	Meets the EMI and RFI requirements for EN 61326-1.
Power Supply:	10 to 42 V dc.
Supply Current:	10 mA dc nominal.
Electronics Housing:	Aluminum housing with epoxy finish. ▶ 84F/W: Remote or integrally mounted to flowtube. With remote mount, interconnecting cable up to 50 ft (15 m) required. ▶ 84S: Remote mounted only. A 15 ft (4.5 m) cable integral to flowtube is provided.
Electronics:	Enclosed in a NEMA 4X (IEC IP66) housing sealed with O-rings for protection against moisture or other contaminants, optional integral LCD indicator with on-board configuration pushbuttons.
Body and Shedder Bar	84F: 316 ss up to 4 in (DN 100) sizes; and 304 ss greater than 4 in (DN 100) sizes.
Materials:	84W: 316 ss for all sizes, or nickel alloy CW2M (equivalent to Hastelloy® C-4C) for 3/4 to 4 in (DN 15 to DN 100) sizes 84S: 316 ss tube and 316L ss shedder bar.
Flowmeter Sizing:	Sizing tools with free web site access at www.FlowExpertPro.com .
Electrical Classification:	Refer to Electrical Safety Specifications table.
Model Code:	Model 84F: Flanged Body, LOW POWER Vortex Flowmeter, or equivalent. Model 84W: Wafer Body, LOW POWER Vortex Flowmeter, or equivalent. Model 84S: Sanitary, LOW POWER Vortex Flowmeter, or equivalent.

DIMENSIONS - NOMINAL

84F (FLANGED) AND 84W (WAFER BODY) FLOWMETERS; INTEGRAL MOUNT; SINGLE MEASUREMENT

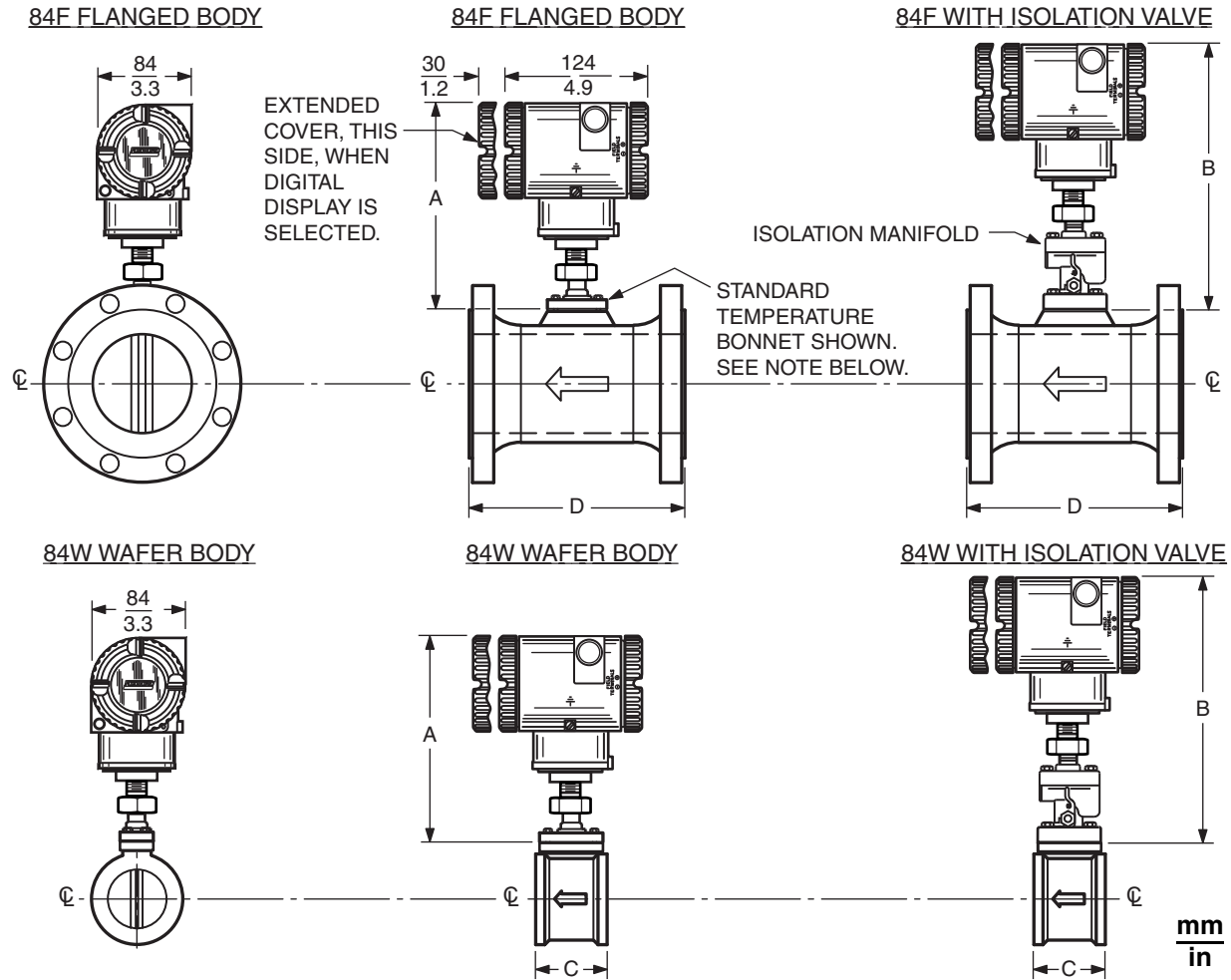

Dimension	Dimensions - Nominal Line Size Code (a)									
	3Q	01	1H	02	03	04	06	08	10 (b)	12 (b)
A (c)	$\frac{173}{6.8}$	$\frac{173}{6.8}$	$\frac{173}{6.8}$	$\frac{173}{6.8}$	$\frac{173}{6.8}$	$\frac{173}{6.8}$	$\frac{173}{6.8}$	$\frac{173}{6.8}$	$\frac{173}{6.8}$	$\frac{173}{6.8}$
B (c)	$\frac{269}{10.6}$	$\frac{269}{10.6}$	$\frac{269}{10.6}$	$\frac{269}{10.6}$	$\frac{269}{10.6}$	$\frac{269}{10.6}$	$\frac{269}{10.6}$	$\frac{269}{10.6}$	$\frac{269}{10.6}$	$\frac{269}{10.6}$
C	$\frac{79.5}{3.13}$	$\frac{79.5}{3.13}$	$\frac{79.5}{3.13}$	$\frac{79.5}{3.13}$	$\frac{95.3}{3.75}$	$\frac{120.7}{4.75}$	$\frac{177.8}{7.00}$	$\frac{228.6}{9.00}$	N/A	N/A
D	Dimension D varies with flange type, rating, and size used. See Table 7 for dimensions.									

(a) Refer to Model Code section for line sizes; refer to DP 019-120 for additional 84F dimensions, and DP 019-122 for additional 84W dimensions.

(b) Size Codes 10 and 12 are not available with wafer body flowtubes.

(c) Dimensions A and B are shown with the standard temperature bonnet. A longer bonnet is used in extended temperature applications; when this selection is made, add 3.6 in (91.4 mm) to Dimensions A and B.

84F FLANGED FLOWMETER: INTEGRAL MOUNT: DUAL MEASUREMENT

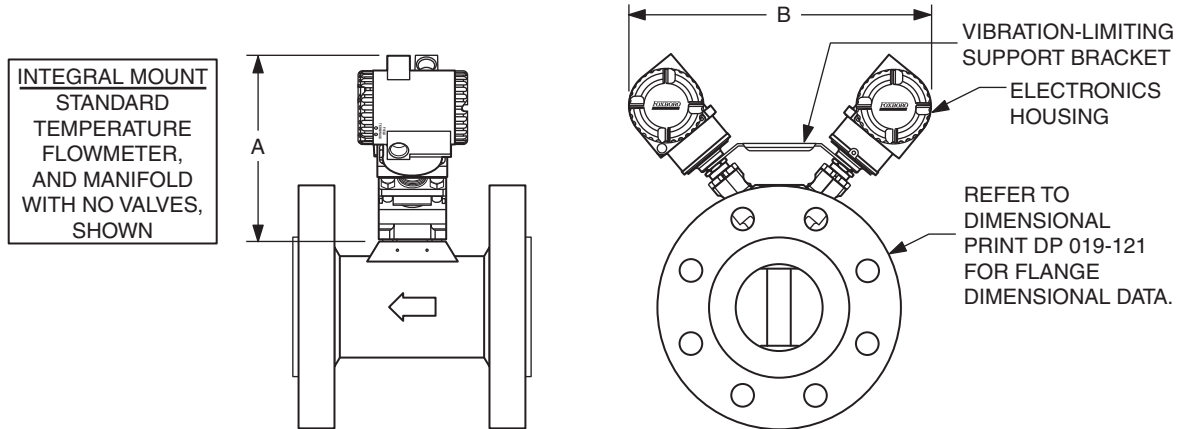

Dimension	Standard Temperature Flowmeter		Extended Temperature Flowmeter	
	No Isolation Valves	With Isolation Valves	No Isolation Valves	With Isolation Valves
A	7.8 in (199 mm)	8.9 in (226 mm)	11.3 in (287 mm)	12.0 in (306 mm)
B	13.9 in (353 mm)	14.3 in (363 mm)	19.7 in (500 mm)	20.7 in (526 mm)

84F FLANGED FLOWMETER: REMOTE MOUNT: DUAL MEASUREMENT

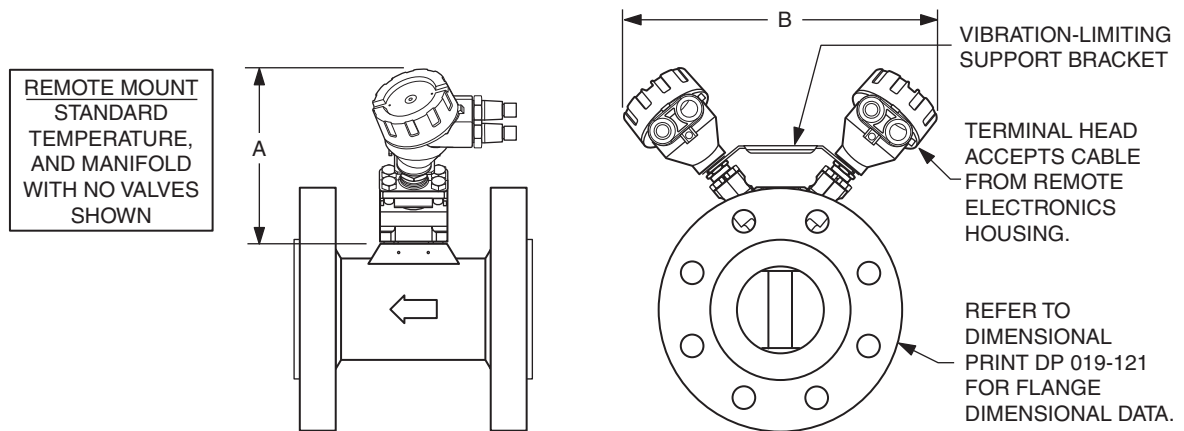

Dimension	Standard Temperature Flowmeter		Extended Temperature Flowmeter	
	No Isolation Valves	With Isolation Valves	No Isolation Valves	With Isolation Valves
A	7.0 in (178 mm)	8.9 in (226 mm)	11.3 in (287 mm)	12.0 in (306 mm)
B	13.9 in (353 mm)	14.3 in (363 mm)	19.7 in (500 mm)	20.7 in (526 mm)

Refer to DP 019-121 for further dimensions.

84F (FLANGED) AND 84W (WAFER BODY) FLOWMETERS WITH REMOTE MOUNTED ELECTRONICS

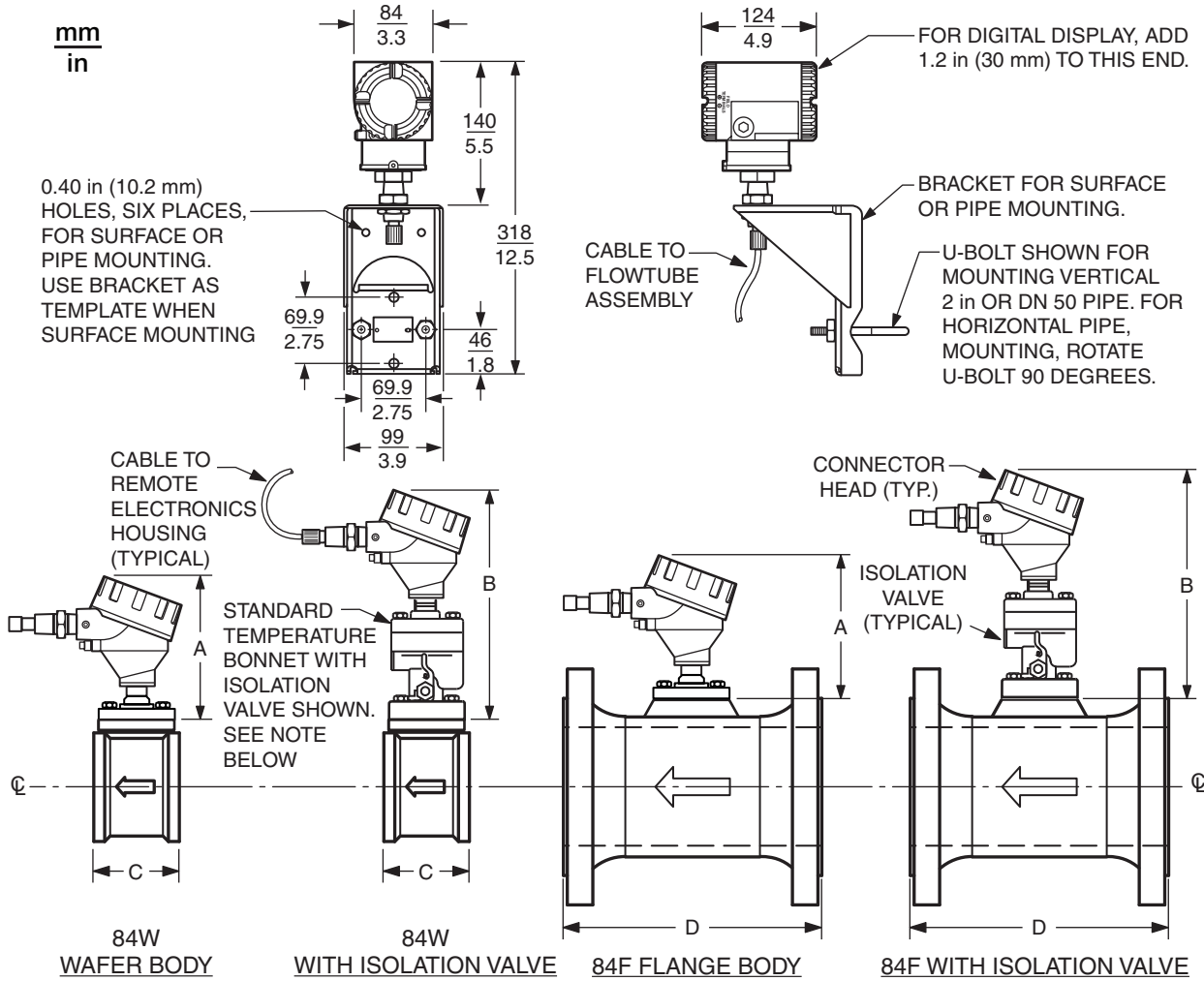

Dimension	Dimensions - Nominal Line Size Code (a)									
	3Q	01	1H	02	03	04	06	08	10 (b)	12 (b)
A (c)	$\frac{173}{6.8}$	$\frac{173}{6.8}$	$\frac{173}{6.8}$	$\frac{173}{6.8}$	$\frac{173}{6.8}$	$\frac{173}{6.8}$	$\frac{173}{6.8}$	$\frac{173}{6.8}$	$\frac{173}{6.8}$	$\frac{173}{6.8}$
B (c)	$\frac{269}{10.6}$	$\frac{269}{10.6}$	$\frac{269}{10.6}$	$\frac{269}{10.6}$	$\frac{269}{10.6}$	$\frac{269}{10.6}$	$\frac{269}{10.6}$	$\frac{269}{10.6}$	$\frac{269}{10.6}$	$\frac{269}{10.6}$
C (d)	$\frac{79.5}{3.13}$	$\frac{79.5}{3.13}$	$\frac{79.5}{3.13}$	$\frac{79.5}{3.13}$	$\frac{95.3}{3.75}$	$\frac{120.7}{4.75}$	$\frac{177.8}{7.00}$	$\frac{228.6}{9.00}$	N/A	N/A
D (d)	Dimension D varies by with flange type, rating, and size used. See Table 7 for dimensions.									

- (a) Refer to Model Code section for line sizes; refer to DP 019-120 for additional 84F dimensions, and DP 019-122 for 84W dimensions.
- (b) Size Codes 10 and 12 are not available with wafer body flowtubes.
- (c) Dimensions A and B are shown with the standard temperature bonnet. With extended temperature applications, add 3.6 in (91.4 mm) to dimensions A and B for the longer bonnet.
- (d) Dimensions C and D are face-to-face dimensions.

Table 7. Dimension “D”

ANSI Flanges per ASME B16.5			Metric Flanges per EN 1092-1		
Line Size	Flange Rating	Dimension “D” (a)	Line Size	Flange Rating	Dimension “D” (b)
3/4 in	Class 150	6.00 in	DN 15	PN 40	152 mm
	Class 300	6.00 in		PN 100	160 mm
	Class 600	6.50 in	DN 25	PN 40	166 mm
1 in	Class 150	6.50 in		PN 100	178 mm
	Class 300	6.50 in	DN 40	PN 40	179 mm
	Class 600	7.00 in		PN 100	199 mm
1 1/2 in	Class 150	7.25 in	DN 50	PN 40 (c)	193 mm
	Class 300	7.25 in		PN 63	202 mm
	Class 600	7.88 in		PN 100	211 mm
2 in	Class 150	7.75 in	DN 80	PN 40 (c)	220 mm
	Class 300	7.75 in		PN 63	230 mm
	Class 600	8.50 in		PN 100	242 mm
3 in	Class 150	8.75 in	DN 100	PN 40	240 mm
	Class 300	8.75 in		PN 63	250 mm
	Class 600	9.50 in		PN 100	268 mm
4 in	Class 150	9.50 in	DN 150	PN 16	305 mm
	Class 300	9.50 in		PN 40	320 mm
	Class 600	10.50 in		PN 63	360 mm
12.00 in		PN 100		360 mm	
6 in	Class 150	12.00 in	DN 200	PN 16	381 mm
	Class 300	12.75 in		PN 40	396 mm
	Class 600	14.75 in		PN 63	443 mm
8 in	Class 150	15.00 in	DN 250	PN 100	443 mm
	Class 300	15.75 in		PN 16	316 mm
	Class 600	18.00 in	PN 40	408 mm	
10 in	Class 150	15.00 in	DN 300	PN 63	481 mm
	Class 300	16.20 in		PN 16	358 mm
12 in	Class 150	17.00 in		PN 40	461 mm
	Class 300	18.20 in	PN 63	513 mm	

- (a) For 3/4 to 4 in sizes, overall face-to-face length (D) tolerance is ± 0.11 in.
For 6 to 12 in sizes overall face-to-face length (D) tolerance is ± 0.250 in.
- (b) For DN 15 to DN 100 sizes, overall face-to-face length (D) tolerance is ± 2.8 mm.
For DN 150 to DN 300 sizes, overall face-to-face length (D) tolerance is ± 6.4 mm.
- (c) May be used with PN 25 mating flange.

84S FLOWMETER WITH REMOTE MOUNTED ELECTRONICS HOUSING

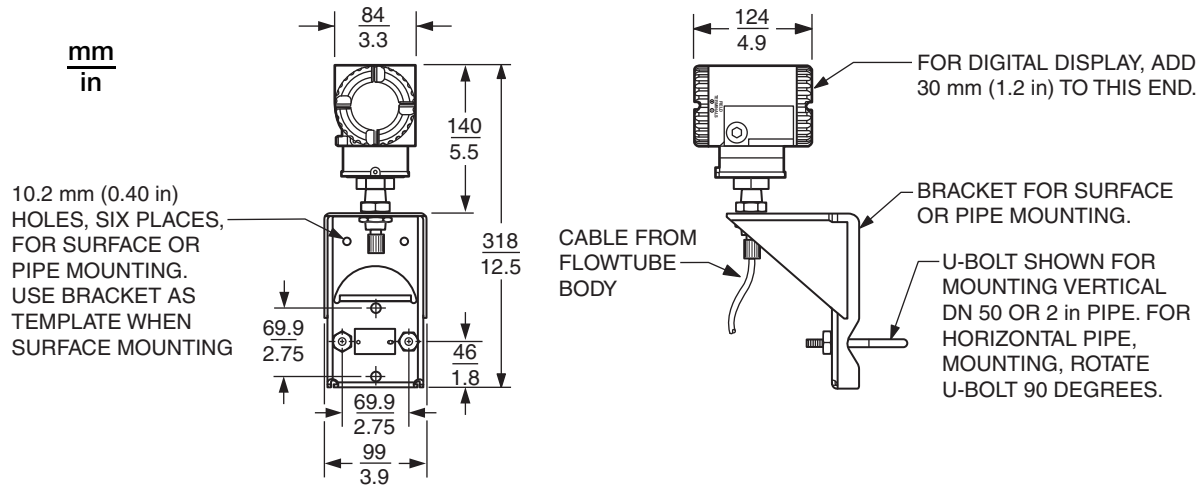

FLOWTUBE BODY

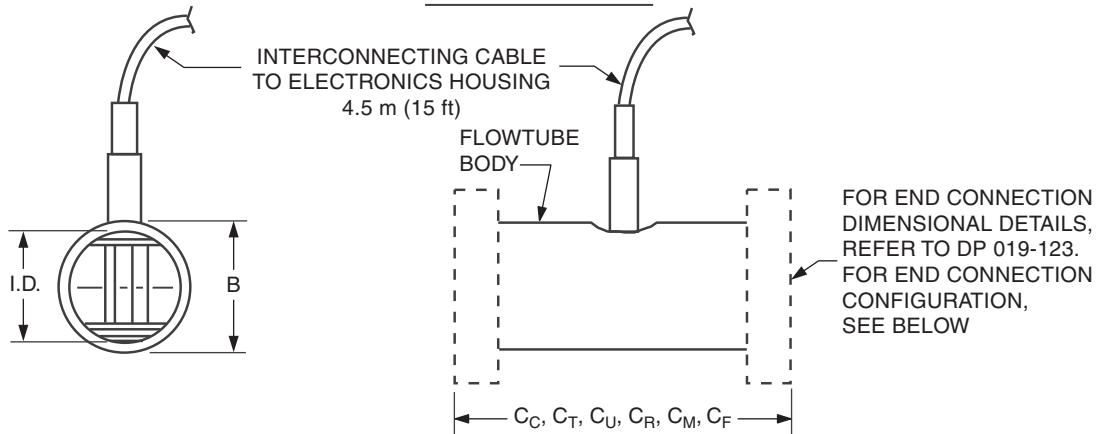

Line Size		I.D.	B	Face-to-Face Dimensions					
mm	in			C _C	C _T	C _U	C _R	C _M	C _F
DN 50	2	$\frac{47.50}{1.870}$	$\frac{50.8}{2.00}$	$\frac{155}{6.1}$	$\frac{127}{5.0}$	$\frac{145}{5.7}$	$\frac{160}{6.3}$	$\frac{173}{6.8}$	$\frac{254}{10.0}$
DN 80	3	$\frac{72.90}{2.870}$	$\frac{76.2}{3.00}$	$\frac{213}{8.4}$	$\frac{178}{7.0}$	$\frac{196}{7.7}$	$\frac{211}{8.3}$	$\frac{334}{9.2}$	$\frac{251}{9.9}$

END CONNECTION CONFIGURATIONS

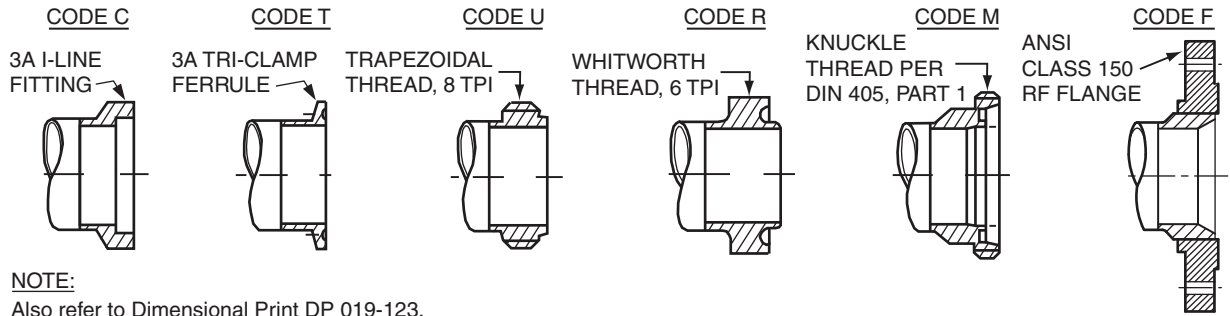

NOTES

ORDERING INSTRUCTIONS

1. Model Number.
2. Flow Data:
 - a. Maximum, minimum, and normal flow rate.
 - b. Fluid composition and viscosity at operating temperatures.
 - c. Fluid density or relative density (specific gravity).
 - d. Maximum, minimum, and normal operating temperatures.
 - e. Maximum, minimum, and normal operating pressures.
 - f. Mating pipe schedule.
 - g. Type and location (distance) of upstream disturbances.
3. Calibration Information (analog output only); maximum flow rate at 20 mA output. If meter is not to be calibrated, add Note: "Calibration not required".
4. Optional Selections and Accessories:
Select from Model Code or "Optional Selections and Accessories" section
5. Customer Tag Data.
6. If meter is to be used in the European countries, then meter must have P.E.D. Certification.

OTHER M&I PRODUCTS

Invensys provides a broad range of measurement and instrument products, including solutions for pressure, flow, analytical, positioners, temperature, controlling and recording. For a listing of these offerings, visit the Invensys Operations Management web site at:

www.iom.invensys.com

Invensys Operations Management
5601 Granite Parkway Suite 1000
Plano, TX 75024
United States of America
<http://iom.invensys.com>

Global Customer Support
Inside U.S.: 1-866-746-6477
Outside U.S.: 1-508-549-2424 or contact
your local Invensys representative.
Website: <http://support.ips.invensys.com>

Invensys, Foxboro, I/A Series, ActiveTuning,
DirectSense, and FlowExpertPro are trademarks of
Invensys plc, its subsidiaries, and affiliates.
All other brand names may be trademarks of their
respective owners.

Copyright 2010-2013 Invensys Systems, Inc.
All rights reserved