

Model 43AP
Pneumatic Indicating Controller
—
Style B

MODEL CODE

<u>Description</u>	<u>Model</u>
Pneumatic Indicating Controller	43AP
<u>Mounting</u>	
Field, NEMA® 3 Enclosure 2-Inch Pipe or Element Yoke Mounted	-F
Panel or Surface	-P
<u>Type of Control</u>	
On-Off	A1
Proportional 4 to 400%	A2
Proportional + Derivative 0.05 to 50 Minutes	A3
Proportional + Reset 0.01 to 50 Minutes per Repeat	A4
Proportional + Reset + Derivative	A5
Differential Gap 1 to 100%	A7
Automatic Shutdown	A8
<u>Output Signal and Gauge</u>	
3 to 15 psi signal; 30 psi gauge	2
0.2 to 1.0 kg/cm ² signal; 2 kg/cm ² gauge	4
20 to 100 kPa signal; 200 kPa gauge	5
0.2 to 1.0 bar signal; 2 bar gauge	6
<u>Auto/Manual Switch</u>	
Bumpless with 2-Position Switch, Balance Gauge, Regulator	C
2-Position Nozzle Seal Switch for Manual Control	D
None	N
<u>Optional Selection</u>	
Remote Pneumatic Set Point	P

*Parts preceded by an asterisk are recommended spare parts.
Give Instrument Model Number and Style when ordering.
See Recommended Spare Parts Summary section for quantities.

TO ORDER PARTS, CALL INVENSYS SYSTEMS INC. AT 1-866-746-6477.



43AP PNEUMATIC CONTROLLER, STYLE B (FIGURE 1)

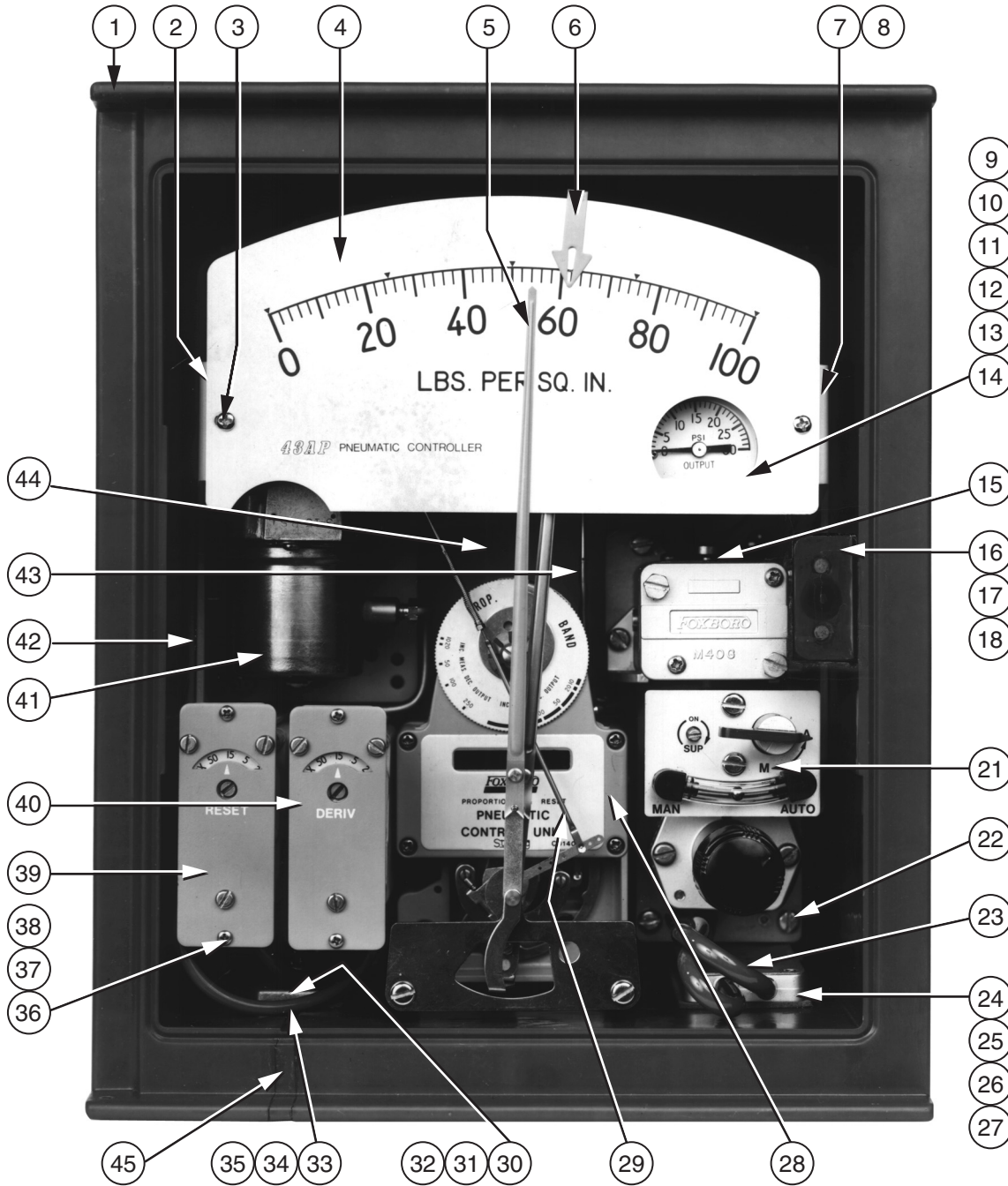

Items 1-18 – Standard Parts (Figure 1)

Item	Part No.	Qty.	Part Name
1	-	1	Case (give instrument serial number)
2	Below	1	Bracket, Left-Hand
	D0138KY		Pressure, Temperature, Receiver, Type 37 Element
	M0154UZ		Pressure (long helical)
3	X0167TJ	2	Screw, panhead, 0.123-20 x 0.250
4	-	1	Dial (give instrument serial number)
5	M0154XW	1	Measurement Pointer
6	M0154XX	1	Setting Index

Items 1-18 – Standard Parts (Figure 1) (Cont.)

Item	Part No.	Qty.	Part Name
7	D0138KY	1	Bracket, Right-Hand
8	X0169DL	4	Sems, panhead, 0.190-32 x 0.313
9	X0100CF	2	Screw, fillister head, 0.164-32 x 0.250
*10	R0128AA	–	Tubing (order 1 m [3 ft] per instrument)
11	C0128FK	1	Insert (seals tubing in gauge base)
12	C0128MF	1	Connection Assembly
*–	C0123AS	1	O-ring, 4.5 mm (0.18 in) ID
13	M0151AL	1	Base
14	Below	1	Output Gauge
	M0154WC		0 to 200 kPa (a)
	M0154WB		0 to 30 psi (a)
	K0129AA		0 to 30 psi (ss element and case) (a)
	D0156FC		0 to 2 kg/cm ²
	M0154XL		0 to 2 bar (a)
15	C0128MF	1	Connection Assembly
*–	C0123AS	1	O-ring, 4.5 mm (0.18 in) ID
16	M0154XR	1	Latch Bracket
17	X0124GJ	4	Screw, flathead, 0.164-32 x 0.375
18	X0167AJ	2	Keps, 0.164-32

(a) Includes Items 10 and 13.

NOTE

1. For Batch Switch and associated parts, refer to PL 004-490.
2. For Differential Flow Element parts, refer to PL 003-320 (Type 37 Element).
3. For Relative Humidity Element, refer to PL 002-613.
4. For Electronic Servo Element, refer to PL 004-488.

Items 21-27 – Optional Auto-Manual Transfer System (Figure 1)

Item	Part No.	Qty.	Part Name
21	C0146PD	1	Auto-Man Transfer System (also see Figure 5)
22	X0169ZY	3	Sems, panhead, 0.164-32 x 1.125
*23	C0140ZH	2	Tube
24	C0140QA	1	Manifold Assembly
*25	U0103FP	2	Screen
26	X0169LP	2	Screw, panhead, 0.190-32 x 0.375
27	Below	1	Gasket
	C0140QQ		Standard
	M0151CK		Vented Case Application
28	–	1	Control Unit (see Figure 2)
29	Below		Adjustable Link Assembly
	X0101BE		Pressure (helical, spiral) Absolute Pressure (double spirals)
	X0101BM		Temperature, Receiver Pressure (bellows, 50 mm [2 in] diaphragm) Type 37 Meter
	X0101CW		Pressure (long helical)
	X0101BK		Pressure (75 mm [3 in] diaphragm)
	X0101CY		Absolute Pressure (bellows)

43AP PNEUMATIC CONTROLLER, STYLE B (FIGURE 1) (Cont.)

Items 30–32 – Pressure Connection Parts (Figure 1)

Item	Part No.	Qty.	Part Name
30	Below	1	Pressure Connection (when used)
	M0154RY		Brass, 1/4 NPT, 0 to 14 MPa (0 to 2000 psi)
	M0154SD		ss, 1/4 NPT, 0 to 14 MPa (0 to 2000 psi)
	M0154SJ		ss, 1/2 NPT, 14 to 70 MPa (2001 to 10,000 psi)
	M0154SG		ss, 9/16-18 Aminco, 70 to 210 MPa (10,001 to 30,000 psi)
	M0154WW		Brass, R 1/4, 0 to 14 MPa (0 to 2000 psi)
	M0154WU		ss, R 1/4, 0 to 14 MPa (0 to 2,000 psi)(see Note)
	M0154WT		ss, R 1/2, 14 to 70 MPa (2001 to 10,000 psi)(see Note)
–	X0107AA	2	Sleeve – Bronze Elements
–	U0100CB	2	Compression Screw – Bronze Elements
–	B0102XL	2	Sleeve – ss Elements
–	B0102XK	2	Compression Screw – ss Elements
31	X0169LP	3	Screw, panhead, 0.190-32 x 0.375
32	Below	1	Gasket
	B0101LK		Pressure
	M0154KY		Filled Systems

— NOTE

For IS07 pressure connections, substitute M0154WW for M0154RY, M0154WU for M0154SD, and M0154WT for M0154SJ. Not available in U.S. area.

Items 33-40 – Optional Restrictor Unit Parts (Figure 1)

Item	Part No.	Qty.	Part Name
*33	C0138NZ	–	Tubing (order 1.3 m [4 ft] per instrument)
34	C0137RT	1	Tee, Tubing
35	C0128NE	2	Coupling, Tubing
36	0032491	2	Screw, panhead, 0.099-48 x 0.188
37	C0131DM	1-2	Bracket
38	X0169CM	2-4	Screw, panhead, 0.138-32 x 0.188 (holds Item 37)
39	C0131CF	1	Restrictor Unit, Integral Reset
40	C0131CG		Restrictor Unit, Derivative
41	–	1	Measuring Element (give instrument serial number)
42	M0154PK	2	Side Mounting Plate

Optional Pneumaticset Unit Parts (Figure 1)

Item	Part No.	Qty.	Part Name
–	U0101CP	1	Pneumaticset Unit, (under dial-when used)
–	U0100FW	1	Lever Assembly
–	U0110BM	1	Tube
43	X0101BK	1	Adjustable Link, (connects pneumaticset unit to control unit)
44	–	1	Mounting Plate (give instrument serial number)
45	M0154KU	1	Slot Cover (filled systems)
–	X0167NT	1	1/2 NPT Case Vent Connection (for gas operation)

CONTROL UNIT (FIGURE 2)

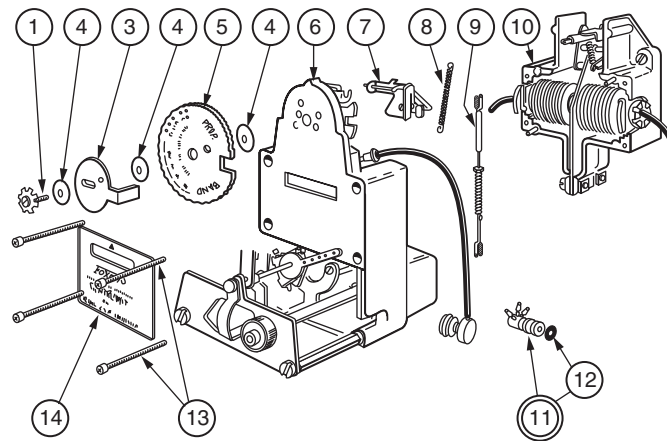

Item	Part No.	Qty.	Part Name
*_	Below		Control Unit
	C0140ZV		On-Off and Automatic Shutdown (Code A8)
	C0140ZU		Proportional and Proportional plus Derivative
	C0140ZS		Proportional plus Integral (reset)
			Proportional plus Integral plus Der. (manual set)
	C0136HV		Proportional plus Integral for Pneumaticset
	C0140ZT		Differential Gap
1	C0128ES	1	Screw Assembly
3	C0128EP	1	Plate
4	C0128CE	4	Washer, 4.4 mm (0.17 in) hole
5	Below	1	Dial
	C0128EN		Used in C0140ZW
	C0128KB		Used in C0140ZU, C0140ZS, C0136HV
	C0128MC		Used in C0140ZT
6	-	1	Subassembly, Front Half (Figure 3)
*7	C0128EX	1	Flapper Assembly
8	C0128EF	1	Spring
9	X0101MM	1	Link, Adjustable, 67 to 83 mm (2.6 to 3.3 in)
10	-	1	Base Assembly, rear half (Figure 4)
11	Below	1	Connection Assembly
	C0128MF		Used with C0140ZV, C0140ZT (one connection)
	C0128KE		Used with C0140ZU (two connections)
	C0128LW		Used with C0140ZS, C0136HV (three connections)
*12	C0123AS	1	O-ring, 4.5 mm (0.18 in) ID
13	X0116PE	4	Screw, fillister head, 0.125-40 x 1.125
14	Below	1	Label
	C0140ZZ		Used in C0156GA
	C0140ZY		Used in C0156GB
	C0140ZW		Used in C0156GC, C0156GP
	C0140ZX		Used in C0156GD
-	C0128NE	2	Tubing Coupling

CONTROL UNIT SUBASSEMBLY (FIGURE 3 – Also See Item 6, Figure 2)

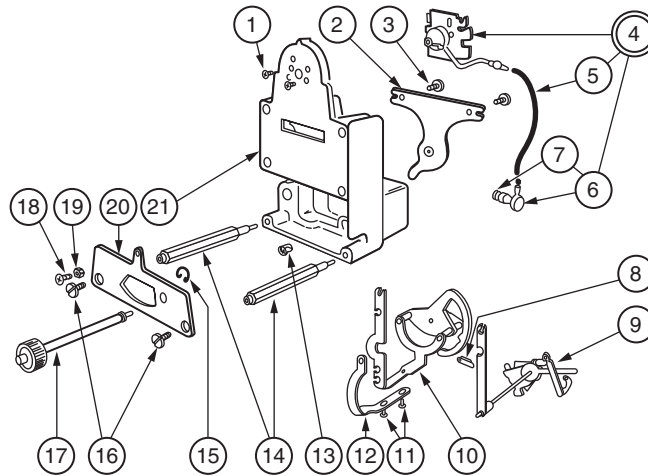

Item	Part No.	Qty.	Part Name
1	X0119PX	2	Screw, flathead, 0.086-56 x 0.18
2	C0140ZG	1	Plate
3	0009577	2	Sems, panhead, 0.164-32 x 0.313
*4	Below C0128CB C0128LZ	1	Nozzle Assembly Used in C0140ZV, C0140ZU, C0140ZS, C0136HV Used in C0140ZT
*5	C0130AR	1	Tube
6	Below C0128MF C0128KE	1	Connection Used in C0128CB Used in C0128LZ
*7	C0123AS		O-ring, 4.5 mm (0.18 in) ID
*8	M0133AF	1	Link Assembly
9	C0140GJ	1	Arbor Assembly
10	C0140ZR	1	Bracket Assembly
11	X0100RA	2	Screw, panhead, 0.086-56 x 0.188
12	C0140ZE	1	Lever Assembly
13	C0128CA	1	Bearing Liner (manual set only)
14	C0128CP	2	Column
15	X0106BZ	1	Retaining Ring (manual set only)
16	X0100PM	2	Screw, panhead, 0.164-32 x 0.250
17	C0128CR	1	Shaft Assembly (manual set only)
18	C0140ZJ	1	Bearing Screw
19	0043480	1	Nut, 0.086-56
20	C0140ZK	1	Plate
21	C0140PA	1	Base

CONTROL UNIT, ON-OFF AND AUTOMATIC SHUTDOWN (CODE A8) - Also see Figure 2

Item	Part No.	Qty.	Part Name
-	C0140ZV	1	Control Unit
-	C0136AN	1	Connection Assembly
-	C0128MF	1	Connection
-	R0128AA	-	Tube, Neoprene; Order 0.3 m (1 ft) per unit
-	C0136AL	1	Manual Start Assembly
-	C0136AE	1	Mounting Bracket
-	0012901	2	Screw, round head, 0.190-32 x 0.312
-	0013317	2	Screw, round head, 0.164-32 x 0.312
-	C0136AM	1	Clamp
-	0024272	1	Screw, round head, 0.138-32 x 0.625

CONTROL UNIT BASE ASSEMBLY (FIGURE 4 – Also see Item 10, Figure 2)

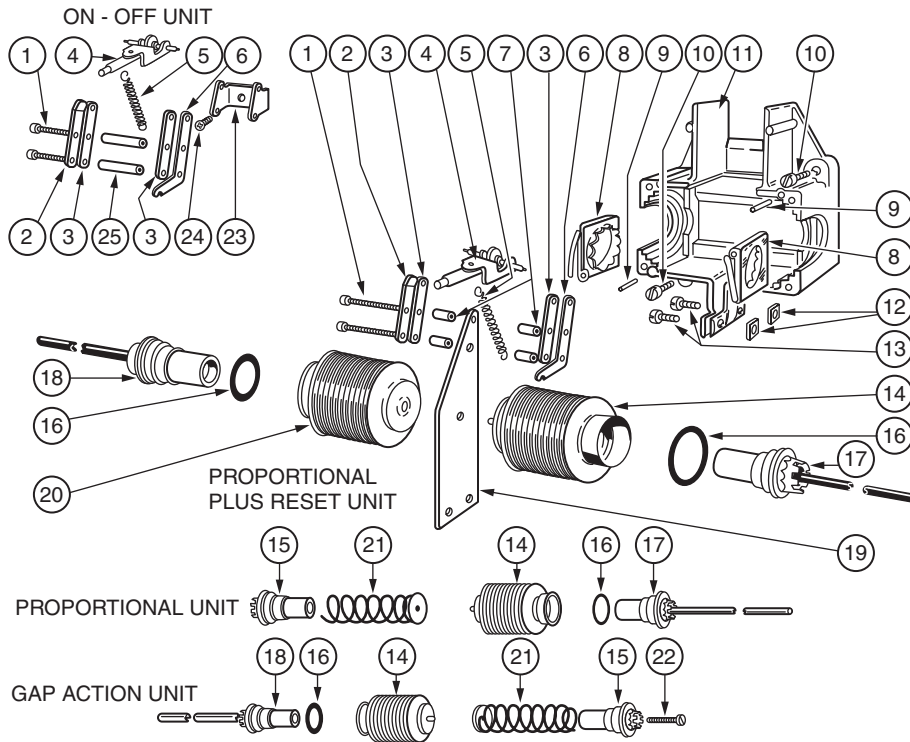

Control Unit C0140ZV (On-Off and Automatic Shutdown) uses Base Assembly C0128CX.
 Control Unit C0140ZU (Proportional and Proportional plus Derivative) uses Base Assembly C0128FF.
 Control Unit C0140ZS (P+I; P+I+D) uses Base Assembly C0128KM.
 Control Unit C0136HV (P+I+Pneumatic Set) uses Base Assembly C0128KM.
 Control Unit C0140ZT (Differential Gap) uses Base Assembly C0140MB.

Item	Part No.	Part Name	Base Assembly			
			C0128CX	C0128FF	C0128KM	C0140MB
1	M0103AE	Screw, fillister head 0.099-48 x 0.750	2	2	2	2
2	B0152MM	Spring	1	1	1	1
3	C0144BL	Plate	2	2	2	2
4	C0132MK	Arbor Assembly	1	1	1	1
5	M0152AC	Spring	1	1	1	1
6	C0128FW	Plate	1	1	1	1
7	C0128FX	Column	–	4	4	4
8	C0128FY	Bellows Lock Spring Assembly	–	2	2	2
9	0043707	Grooved Pin	2	2	2	2
10	X0124FH	Screw, fillister head, 0.164-32 x 0.500	2	2	2	2
–	X0143QJ	Lockwasher	2	2	2	2
11	C0128EL	Base, rear half	1	1	1	–
11	C0144AX	Base, rear half	–	–	–	1
12	X0104KB	Nut, 0.164-32	–	2	2	2
13	X0116MP	Screw, socket head, 0.164-32 x 0.375	–	2	2	2
14	C0162AL	Bellows Assembly	–	1	1	1
15	C0128FP	Bushing Molding	–	1	–	1
16	X0145DV	O-Ring, 17.1 mm (0.67 in) ID	–	1	2	1

Item	Part No.	Part Name	Base Assembly			
			C0128CX	C0128FF	C0128KM	C0140MB
17	D0124QE	Connection Assembly	—	1	1	—
18	D0124QF	Connection Assembly	—	—	1	1
19	C0128EC	Flexure	—	1	1	1
20	C0128KN	Bellows Assembly	—	—	1	—
21	C0128FR	Spring Assembly	—	1	—	1
22	X0100TA	Screw, socket head, 0.190-32 x 1.000	—	—	—	1
23	C0128EK	Bracket	1	—	—	—
24	0024520	Screw, round head, 0.099-48 x 0.188	1	—	—	—
25	C0128EE	Column	2	—	—	—

AUTO-MANUAL TRANSFER SYSTEM (FIGURE 5 - Also see Item 21, Figure 1)

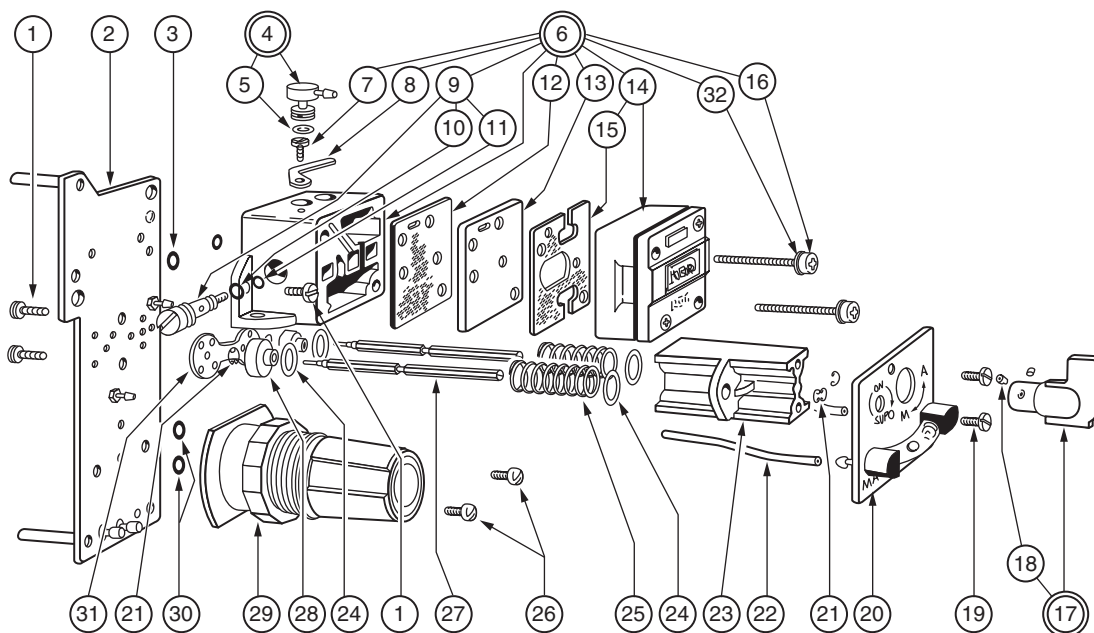

Item	Part No.	Qty.	Part Name
*—	C0146PD	—	Auto-Manual Transfer System
1	C0138KM	4	Sems, panhead, 0.164-32 x 0.375
2	C0140PS	1	Circuit Plate Assembly
*3	C0123AS	2	O-ring, 4.5 mm (0.18 in) ID
4	C0128MF	1	Connector Assy (Assoc. Part)
*5	C0123AS	1	O-ring, 4.5 mm (0.18 in) ID
6	C0146NV	1	Relay Manifold Assembly
7	X6000KL	1	Screw, hex head, 0.138-32 x 0.187
8	U0109EB	1	Clamp Lever
9	C0140GT	1	Orifice Screw Assembly
*10	C0123AS	1	O-ring, 4.5 mm (0.18 in) ID
*11	C0127CM	1	O-ring, 2.9 mm (0.11 in) ID
12	U0110AX	1	Gasket
13	U0113AK	1	Plate
*14	F0108FV	1	Relay Replacement Kit M40K
15	C0100EM	1	Gasket
16	X0127DM	2	Screw, panhead, 0.190-32 x 1.250

Item	Part No.	Qty.	Part Name
17	C0140QX	1	Knob Assembly
18	X0100YT	2	Set Screw, 0.125-40
19	X0100PZ	2	Screw, panhead, 0.164-32 x 0.218
20	C0140QK	1	Tube Assembly
21	C0134EC	4	Retaining Ring
22	R0128AA	-	Tubing (order 0.3 m [1 ft] per unit)
23	C0146PC	1	Column
24	C0134EF	4	Washer
25	C0134AZ	2	Spring
26	X0169CZ	2	Sems, panhead, 0.164-32 x 0.37
27	C0140QY	2	Shaft
28	C0134FA	2	Switch Plate
*29	D0156EZ	1	Regulator
*30	C0100CK	2	O-ring, 9.3 mm (0.36 in) ID
*31	C0136HX	1	Gasket
*32	X0143SC	2	Washer Ext. Tooth #10

RELAY MANIFOLD ASSEMBLY (FIGURE 6)
 (Used if Instrument Does Not Have Auto-Manual Transfer System)

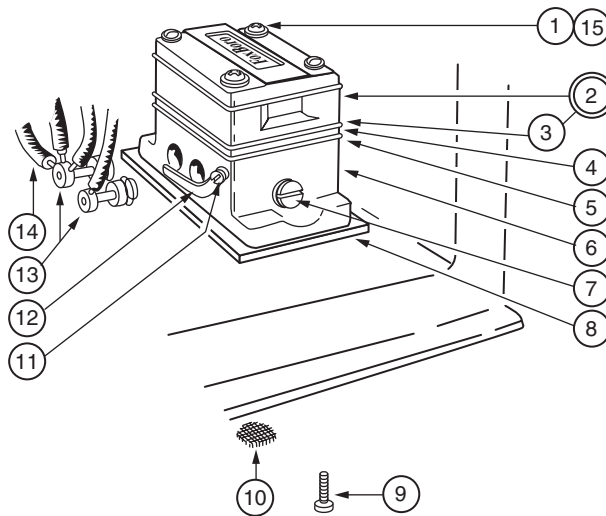

Item	Part No.	Qty.	Part Name
-	C0140GV	-	Relay Manifold Assembly (Items 1-7, 10-12, 15)
1	X0127DM	2	Screw, panhead, 0.190-32 x 1.250
*2	F0108FV	1	Relay Replacement Kit, M40K
*3	C0100EM	1	Gasket
4	U0113AK	1	Plate
5	U0110AX	1	Gasket
6	N0224PS	1	Relay Manifold
*7	C0140GT	1	Orifice Screw Assembly
*-	C0123AS	1	O-ring, 4.5 mm (0.18 in) ID
*-	C0127CM	1	O-ring, 2.9 mm (0.11 in) ID
8	Below	1	Gasket
	C0140QQ		Standard
	M0151CK		Vented Case

Item	Part No.	Qty.	Part Name
9	X0127DD	2	Screw, panhead, 0.190-32 x 0.375
*10	U0103FP	2	Screen
11	X6000KL	1	Screw, hex head, 0.138-32 x 0.218
12	U0109EB	1	Clamp Lever
13	Below	–	Connection Assembly
	C0128MF		One connection
	C0128KE		Two connections
	C0128LW		Three connections
*–	C0123AS	1	O-ring, 4.5 mm (0.18 in) ID
14	R0128AA	–	Tubing (1 m [3 ft] per inst.)
15	X0143SC	2	Washer Ext. Tooth #10

AUTO-MANUAL TRANSFER SWITCH (FIGURE 7)
(Used if Instrument Does Not Have Auto-Manual Transfer System)

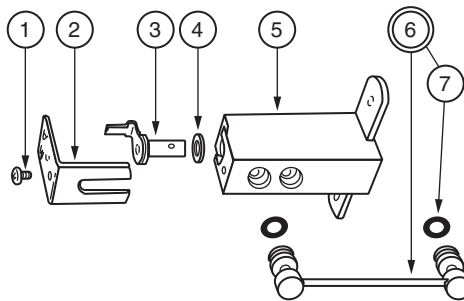

Item	Part No.	Qty.	Part Name
*1-5	C0132KA	–	Transfer Switch Assembly
1	C0132KR	1	Screw, panhead, 0.112-48 x 0.125
2	C0132KF	1	Clip
3	C0132KM	1	Stem Assembly
4	C0100CK	1	O-ring
5	C0132KK	1	Switch Block
6	C0132KB	1	Connector Assembly
*7	C0123AS	2	O-ring, 4.5 mm (0.18 in) ID

**INTERMEDIATE MOVEMENT AND LINKAGES (FIGURE 8)
(For Type 37 Diaphragm Element)**

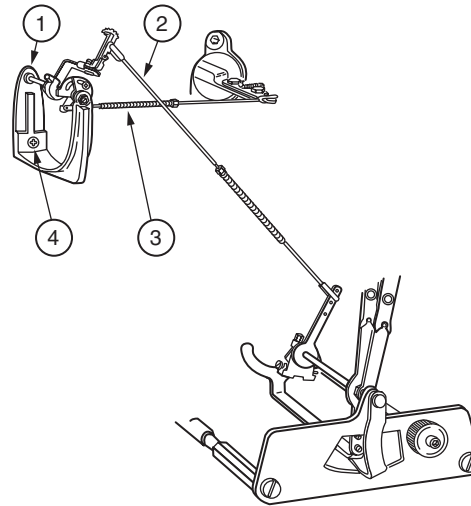

Item	Part No.	Qty.	Part Name
1	M0104LB	1	Intermediate Movement Assembly
2	X0101BM	1	Link, Adjustable 133 to 146 mm (5.3 to 5.8 in)
3	X0101MM	1	Link, Adjustable 67 to 83 mm (2.6 to 3.3 in)
4	0008462	1	Sems, round head, 0.125-40 x 0.375

INTEGRAL RESTRICTOR ASSEMBLY (FIGURE 9)

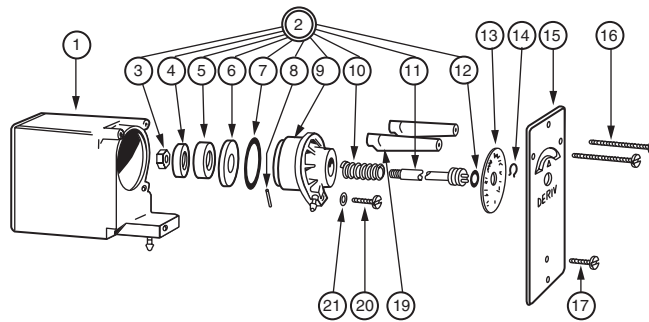

Item	Part No.	Qty.	Part Name
*-	C0131CF	-	Integral (reset) Restrictor Assembly
1	C0131CM	1	Tank Assembly
2	C0131CN	1	Body Assembly
3	X0142BT	1	Nut, 0.250-28
4	C0131DK	1	Washer
5	C0134BE	1	Scratch Restrictor
6	C0131DH	1	Gasket
*7	X0145CM	1	O-ring 21.9 mm (0.86 in) ID
8	0042884	1	Grooved Pin
9	C0131DT	1	Body
10	C0131CV	1	Spring
-	C0134CZ	1	Washer
11	C0131CS	1	Restrictor Shaft

Item	Part No.	Qty.	Part Name
*12	X0145CC	1	O-ring, 7.6 mm (0.30 in) ID
13	C0131CU	1	Dial
*14	C0134CM	1	Retaining Ring
15	C0131DN	1	Cover Plate
16	X0170CE	2	Screw, panhead, 0.123-20 x 1.000
17	X0167TL	1	Screw, panhead, 0.123-20 x 0.375
19	X0118EM	2	Block
20	X0167TN	1	Screw, panhead, 0.123-20 x 0.500
21	X0143EX	1	Washer
-	C0137RT	1	Tee (see Note)
-	C0138BM	1	Cap (see Note)
-	C0129BN	1	Tube Assembly (see Note)

— **NOTE** —
Instruments with External Reset Connection

DERIVATIVE RESTRICTOR ASSEMBLY (FIGURE 10)

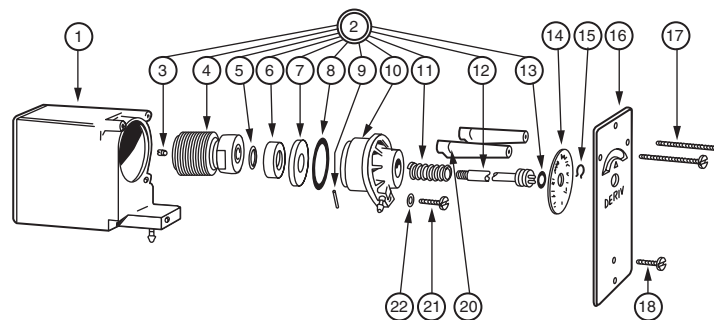

Item	Part No.	Qty.	Part Name
*—	C0131CG	—	Derivative Restrictor Assembly
1	C0131CM	1	Tank Assembly
2	C0131CP	1	Body Assembly
3	C0126RK	1	Stop Screw
4	C0131CW	1	Bellows Assembly
*5	X0145CE	1	O-ring 10.8 mm (0.43 in) ID
6	C0134BE	1	Scratch Restrictor
7	C0131DH	1	Gasket
*8	X0145CM	1	O-ring 21.9 mm (0.86 in) ID
9	0042884	1	Grooved Pin
10	C0131DU	1	Body
11	C0131CV	1	Spring
-	C0134CZ	1	Washer (not shown)
12	C0131CT	1	Restrictor Shaft
*13	X0145CC	1	O-ring, 7.6 mm (0.30 in) ID
14	C0140GR	1	Dial
*15	C0134CM	1	Retaining Ring
16	C0131DP	1	Cover Plate
17	X0170CE	2	Screw, panhead, 0.123-20 x 1.000
18	X0167TL	1	Screw, panhead, 0.123-20 x 0.375
20	X0118EM	2	Block
21	X0167TN	1	Screw, panhead, 0.123-20 x 0.375
22	X0143EX	1	Washer

FLUSH OR SURFACE PANEL MOUNTING PARTS (FIGURE 11)

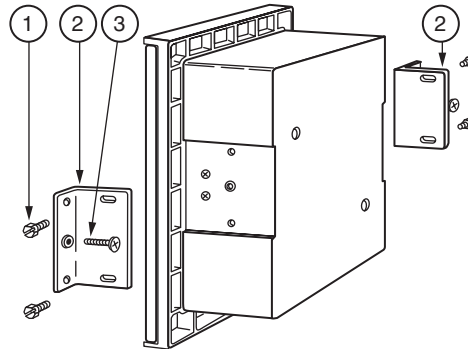

Item	Part No.	Qty.	Part Name
–	M0154TS	–	Mounting Kit
1	X0167GT	4	Screw, hex head, 0.190-32 x 0.375
2	M0154NJ	2	Bracket
3	X0130MS	2	Screw, panhead, 0.312-18 x 1.000

PIPE MOUNTING PARTS FOR TEMPERATURE OR PRESSURE INSTRUMENT (FIGURE 12)

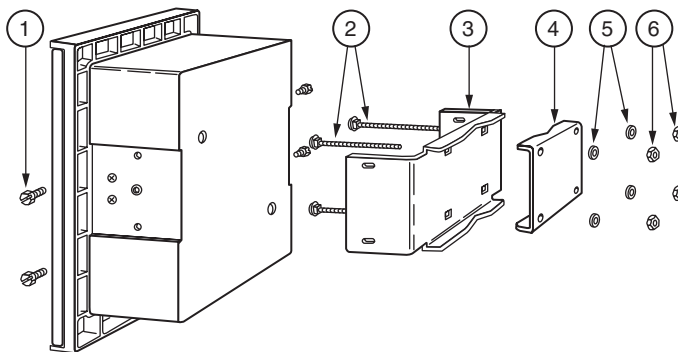

Item	Part No.	Qty.	Part Name
–	M0154TR	–	Mounting Kit
1	X0167GT	4	Screw, hex head, 0.190-32 x 0.375
2	X0116PN	4	Bolt, Carriage, 0.250-20 x 4.000
3	M0154NH	1	Bracket
4	M0154NK	1	Pipe Clamp
5	0005653	4	Washer
6	0012354	4	Nut, 0.250-20

YOKE MOUNTING PARTS FOR INSTRUMENT WITH TYPE 37 DIAPHRAGM ELEMENT (FIGURE 13)

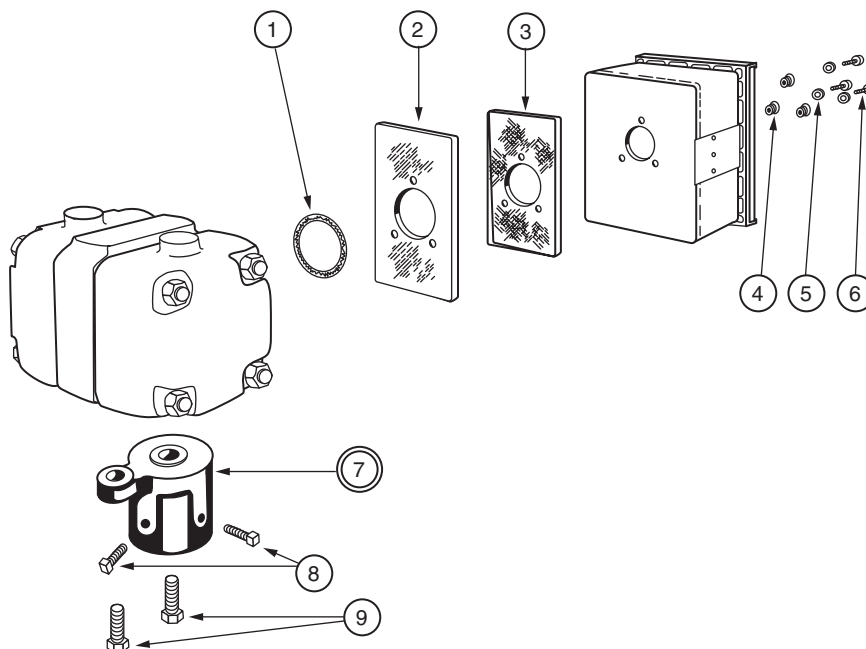

Item	Part No.	Qty.	Part Name
1	D0116FM	1	Gasket
2	M0154VE	1	Plate
3	M0154QU	1	Gasket
4	M0154QD	3	Bushing
5	0048218	3	Lockwasher
6	X0100RM	3	Screw, hex head, 0.375-16 x 1.00
7	D0116AW	1	Mounting Yoke
8	0016809	2	Screw, square head, 0.500-13 x 1.000
9	X0100TT	2	Screw, hex head, 0.312-18 x 1.250

INTEGRAL AIR SUPPLY SET AND PRESSURE GAUGES (FIGURE 14)

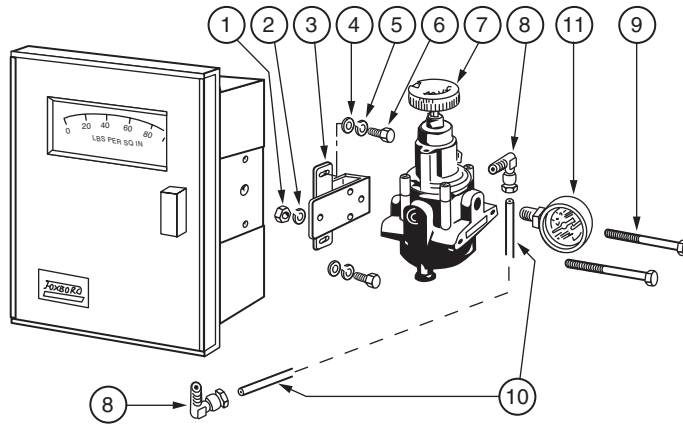

Item	Part No.	Qty.	Part Name
1-10 – Integral Air Supply Set			
–	Below M0154SZ M0154WG	–	Adjustable Pressure Air Set Copper Tubing PVC Coated Tubing
–	Below M0154TC M0154TH	–	Fixed Pressure Air Set Copper Tubing PVC Coated Tubing
1	0011962	2	Nut, 0.312-18
2	X0143SE	2	Lockwasher
3	M0154WD	1	Mounting Bracket
4	X0143FD	2	Washer
5	X0143SC	2	Lockwasher
6	X0127JP	2	Screw, hex head, 0.190-32 x 0.625
*7	Below B0123HE B0123HD	1	Filter Regulator Adjustable Pressure (shown) Fixed Pressure
8	X0172BE	2	Elbow
9	X0100KW	2	Screw, hex head, 0.312-18 x 3.750
10	Below M0154WE M0154WJ	1	Tube Copper PVC Coated
11 – Pressure Gauges			
*11	Below P0103YP P0121BN	1	Pressure Gauge 0 to 30 psi/0 to 2 bar (Dual Scale) 0 to 200 kPa/0 to 2 kg/cm ² (Dual Scale)
*11	P0122JE	1	Pressure Gauge (green band)

DOOR ASSEMBLY (FIGURE 15)

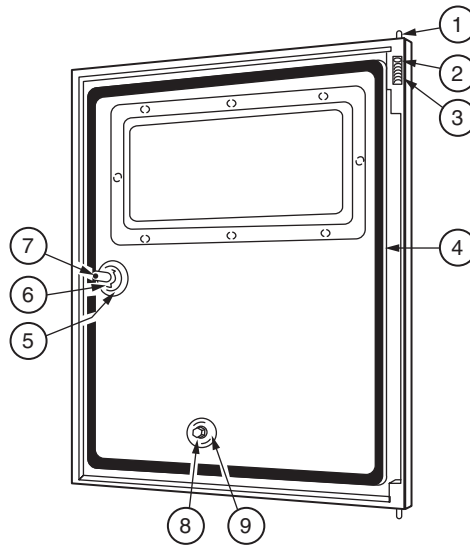

Item	Part No.	Qty.	Part Name
–	M0154NB	–	Door Assembly (internal set) (includes Items 1-4)
–	M0154UT	–	Door Assembly (external set) (includes Items 1-4)
–	M0154VL	–	Door Assembly (shatterproof glass) (includes Items 1-4)
1	M0154NP	1	Pin
2	X0167KH	1	Retaining Washer
3	X0167KE	1	Spring
4	M0154XY	1	Gasket
5	M0154XV	1	Gasket
6	X0106BB	1	Retaining Washer
7	M0154XP	1	Knob
8	M0154UW	1	External Set Knob (for M0154UT)
9	M0151AC	1	Seal (for M0154UT)

Tamperproof Knob Assembly (not shown)

–	M0154XU	1	Knob Assembly
–	M0154XT	1	Key

— NOTE

To replace early model door knobs or latch brackets (with rectangular plastic inserts), order Part No. M0153YB Knob Conversion Kit.

MEASURING ELEMENT MOUNTING PARTS

**Flow, Diaphragm Meter, Type 37 (see Figure 13)
Pressure and Temperature**

Part No.	Qty.	Part Name
Below	1	Adapter Plate
0041518		Pressure - helicals, spirals
0041518		Temperature - Class 1B, 2
U0101AN		Pressure - br. bellows, 50 mm (2 in) dia
M0154NX		Pressure - 75 mm (3 in) dia
Below	–	Column
0038066	2	ss bellows
M0145FL	2	absolute pressure bellows
M0130EP	4	ss long helical
Below	–	Screw, for adapter plate
X0169DL	2	panhead, 0.190-32 x 0.313 (press, temp)
X0169DL	4	panhead, 0.190-32 x 0.313 (ss long helical)

**Flow, Differential Pressure
Type 224, Barton Meter**

Item	Part No.	Qty.	Part Name
–	Below	–	224 Meter, Static 6000 psi max; Span 0-60 to 0-400 psi
	M0155AP		Steel Housing, BeCu Bellows
	M0155AQ		316 ss Housing, 316 ss Bellows
	M0155AR		Steel Housing, 316 ss Bellows

Installation Parts

–	A041398	1	Bearing Extension
–	M0154QB	4	Bushing
–	M0134NK	1	Intermediate Movement
–	P0106PB	1	Base (for M0134NK)
–	M0134NL	1	Micro Lever
–	M0155AS	1	Gasket
–	X0101BM	1	Link, Adjustable 135 to 146 mm (5.3 to 5.8 in)
–	X0101CA	1	Link, Adjustable 62 to 75 mm (2.4 to 2.9 in)
–	0048858	1	Set Screw, 0.112-40 x 0.125
–	0042965	4	Lockwasher
–	0035324	4	Screw, flat head, 0.250-20 x 1.250
–	0022956	4	Nut, 0.250-20
–	0006546	1	Screw, round head, 0.125-40 x 1.000

TYPE 70 ALARM CONTACTS - INTERNAL COMPONENTS (FIGURE 16)

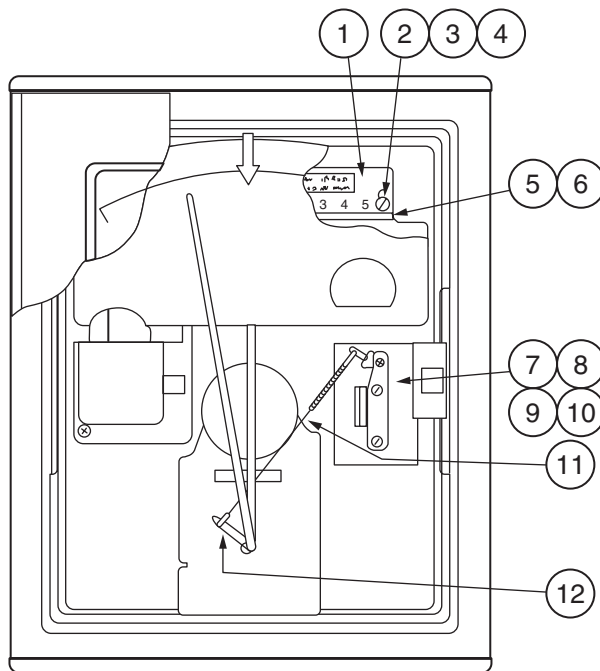

Item	Part No.	Qty.	Part Name
1	M0154TV	1	Plate
2	X0100PN	2	Screw, panhead, 0.138-32 x 0.187
3	M0115AL	2	Column
4	M0130RZ	2	Column
5	0041057	1	Terminal Strip
6	L0104CN	1	Insulator
7	Below	1	Type 70 Contact Assembly
	M0129FM		3 contacts
	M0129KM		5 contacts
8	M0145FL	2	Column
9	X0143SC	2	Washer
10	X0127DD	2	Screw, panhead 0.190-32 x 0.375
11	X0101BE	1	Link, Adjustable 95 to 108 mm (3.8 to 4.3 in)
12	C0129CX	1	Lever Assembly

NOTE

For remote relay housing components, give instrument serial number and wiring circuit code number from data plate.

EARTHING (GROUNDING PARTS) - (FIGURE 17)

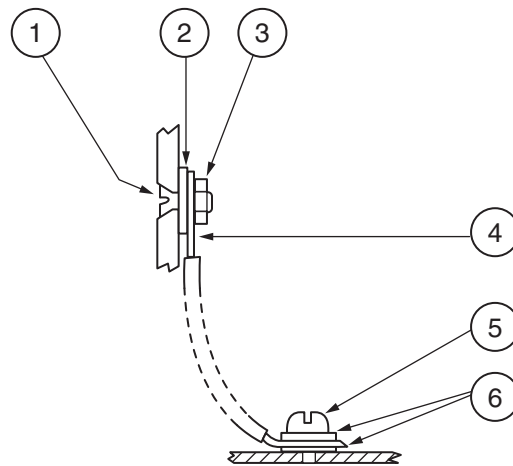

Item	Part No.	Qty.	Part Name
1	X0124GJ	1	Screw, flat head, 0.164-32 x 0.375
2	X0143SB	1	Washer
3	B0105PM	1	Nut, 0.164-32
4	C0140QD	1	Jumper
5	X0169DK	1	Screw, panhead, 0.190-32 x 0.250
6	X0143SC	2	Washer

RECOMMENDED SPARE PARTS SUMMARY

Figure Number	Item Number	Part Number	Part Name	Number of Parts Recommended for		
				1 Inst.	5 Inst.	20 Inst.
1	10	R0128AA	Tubing (order 1 m [3 ft] per instrument)	–	–	–
	–	C0123AS	O-ring (used in connection, Items 12, 15)	4	8	12
	23	C0140ZH	Tube	0	0	2
	25	U0103FP	Screen	0	4	6
	33	C0138NZ	Tubing (order 1.3 m [4 ft] per instrument)	–	–	–
2	–	Below C0140ZV C0140ZU C0140ZS C0136HV C0140ZT	Control Unit On-Off, Automatic Shutdown Proportional, Proportional plus Derivative Proportional plus Integral, Proportional plus Integral plus Derivative Proportional plus Integral (for Pneumaticset Control) Differential Gap	0	0	1
	7	C0128EX	Flapper Assembly	0	1	2
	12	C0123AS	O-ring (used in connection, Item 11)	1	2	3
	–	–	–	–	–	–
3	4	Below C0128CB C0128LZ	Nozzle Assembly Used in C0140ZV/ZU/ZS, C0136HV Used in C0140ZT	0	1	2
	5	C0130AR	Tube	0	1	2
	7	C0123AS	O-ring (used in connection, Item 6)	1	2	3
	8	M0133AF	Link Assembly	0	0	1

RECOMMENDED SPARE PARTS SUMMARY (Cont.)

Figure Number	Item Number	Part Number	Part Name	Number of Parts Recommended for		
				1 Inst.	5 Inst.	20 Inst.
5	–	C0146PD	Auto-Manual Transfer System	0	0	1
	3,5,10	C0123AS	O-ring	4	8	12
	11	C0127CM	O-ring	2	4	6
	30	C0100CK	O-ring	4	6	8
	14	F0108FV	Relay Replacement Kit, M40K	1	1	2
	15	C0100EM	Gasket	1	2	3
	29	D0156EZ	Regulator	0	0	1
	31	C0136HX	Gasket	0	1	2
6	2	F0108FV	Relay Replacement Kit, M40K	1	1	2
	3	C0100EM	Gasket	1	2	3
	7	C0140GT	Orifice Screw Assembly	1	1	2
	–	C0123AS	O-ring			
	–	C0127CM	O-ring			
	10	U0103FP	Screen	2	4	6
–	C0123AS	O-ring (used in connection, Item 13)	1	2	3	
7	–	C0132KA	Transfer Switch Assembly	0	0	1
	7	C0123AS	O-ring (used in connector, Item 6)	2	4	6
9	–	C0131CF	Restrictor Assembly, Integral	0	0	1
	7	X0145CM	O-ring	2	4	6
	12	X0145CC	O-ring	2	4	6
	14	C0134CM	Retaining Ring	2	4	6
10	–	C0131CG	Restrictor Assembly, Derivative	0	0	1
	5	X0145CE	O-ring	2	4	6
	8	X0145CM	O-ring	2	4	6
	13	X0145CC	O-ring	2	4	6
	15	C0134CM	Retaining Ring	2	4	6
14	7	Below B0123HE B0123HD	Filter Regulator Adjustable Pressure Fixed Pressure	0	0	1
	11	Below P0103YP P0121BN P0122JE	Pressure Gauge 0 to 30 psi/0 to 2 bar (Dual Scale) 0 to 200 kPa/0 to 2 kg/cm ² (Dual Scale) Pressure Gauge (green band)	0	0	1



IPS Corporate Headquarters
5601 Granite Parkway Suite 1000
Plano, TX 75024
www.ips.invensys.com

Foxboro Global Client Support
Inside U.S.: 1-866-746-6477
Outside U.S.: 1-508-549-2424 or
contact your local Foxboro
representative.
Facsimile: 1-508-549-4999

Invensys and Foxboro are trademarks of Invensys plc, its
subsidiaries, and affiliates.
All other brand names may be trademarks of their respective
owners.

Copyright 1992-2009 Invensys Systems, Inc.
All rights reserved